

Fitting Instructions

Wiring Instructions for replacing Lucas C45 dynamo

1. Remove field lead (F) and warning light (WL) from regulator and attach together
2. Remove dynamo lead (D) from regulator and attach to battery positive lead to create a battery positive feed.
3. Main alternator feed from battery must be rated at 45 amps minimum.

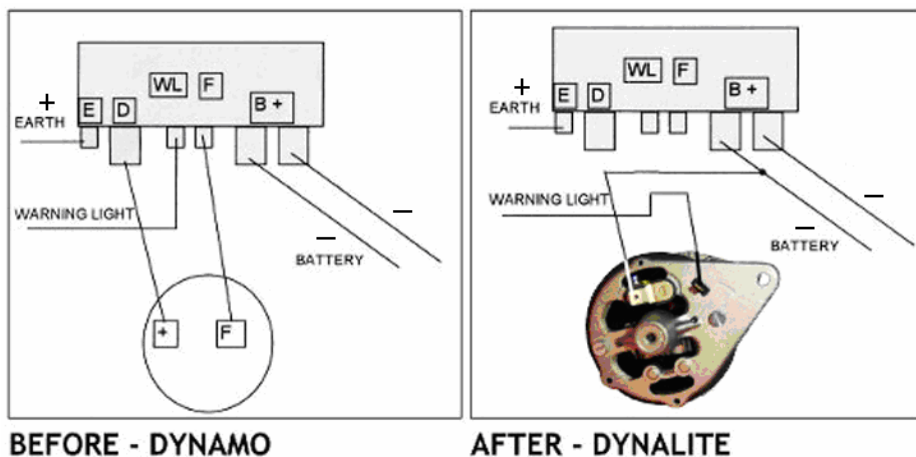

4. Connection of relay (supplied with Dynalite)

Relay comes pre-wired with the earth connection. Break main ignition – warning light wire & wire ignition to 85 and warning light to 87 as per diagram below:

RELAY DIAGRAM

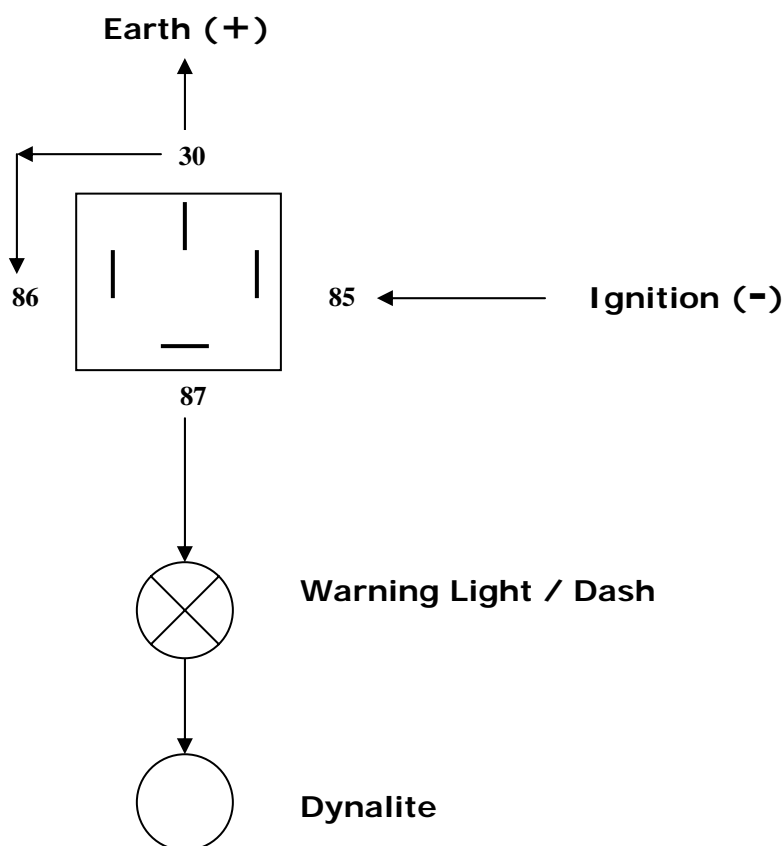

Important Notes

Please ensure that there is a good earth connection – particularly if the car has been recently painted

IF IN DOUBT, PLEASE CONSULT YOUR POWERLITE DEALER OR A QUALIFIED AUTO ELECTRICIAN!!