

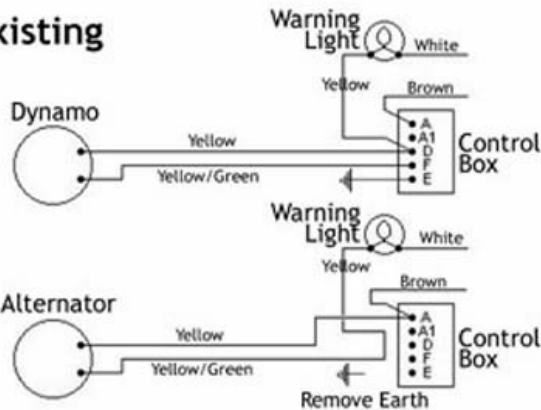

TYPICAL WIRING DIAGRAMS FOR SINGLE WIRE ALTERNATORS

The main terminal is wired back to the battery and the spade terminal is wired back to your warning light (The other side of your warning light is wired to your ignition supply not earth.) The warning light must be wired in for the Alternator to work correctly. Here are some typical installations when replacing a dynamo or multi-wire alternator. You should consult your cars wiring diagram and follow the simple rule above of main terminal is positive supply and spade terminal is warning light. Alternators can only work with negative earth. Ensure your engine earth strap is in good condition or that the engine is otherwise well earthed. If in doubt consult an auto electrician.

Existing



Existing

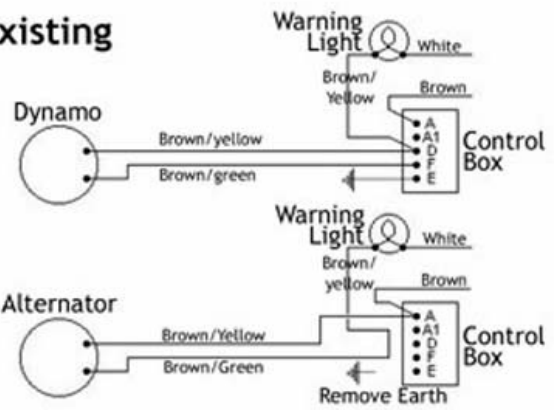

With Alternator/Dynalite

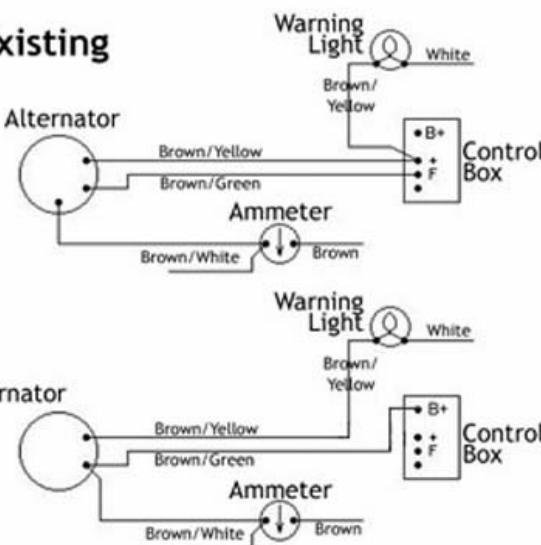

With Alternator/Dynalite

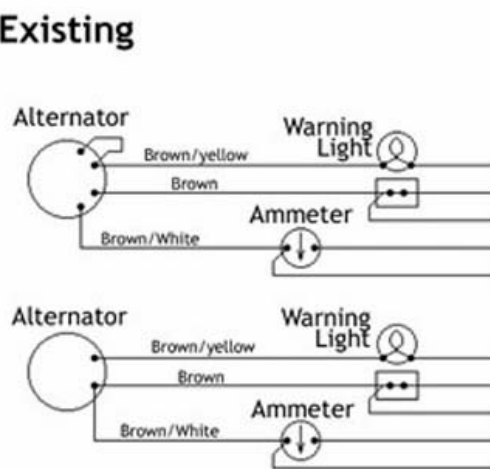

With Alternator

With Alternator

Important Note

Please ensure that there is a good earth connection – particularly if the car has been recently painted