



Auto Electric Supplies Ltd

MAIL ORDER CATALOGUE

Tel: 01584 819552

Fax: 01584 819355

www.autoelectricsupplies.co.uk

info@autoelectricsupplies.co.uk

ISSUE 5
April 2009

IMPORTANT INFORMATION

1. Choice of Items

It is the customer's responsibility to ensure that the selected goods are suitable for their chosen application. Auto Electric Supplies Ltd can take no responsibility or liability for misuse of the goods supplied.

2. Description of Goods

All item descriptions and illustrations are merely intended to present an idea of the goods for sale. As suppliers to Auto Electric Supplies Ltd may change the design or materials used in their products, Auto Electric Supplies Ltd reserves the right to change without notice the designs and/or materials used in the products supplied by it, provided that the specification of the goods is not compromised.

Auto Electric Supplies Ltd are suppliers only of goods in this catalogue and are not the manufacturers of any of the products supplied.

3. Pricing

All catalogue prices shown are in pounds sterling and are exclusive of VAT which will be charged at the standard rate on all items and delivery costs. Due to circumstances beyond our control, prices quoted in the catalogue may vary from time to time. Up to date prices can be found on our web site: www.autoelectricsupplies.co.uk.

4. Returned Goods

If for any reason you are not satisfied with the supplied goods, return them to us, unused, within 10 working days and we will give you a full refund. The returned items can alternatively be exchanged for goods to the same value, or credited to your account. Please note that cut lengths of cable, sleeving, etc. cannot be returned.

5. Catalogue

No liability can be accepted for errors or misprints in this catalogue. No part of this catalogue can be reproduced in any form without the prior written permission of Auto Electric Supplies Ltd. © Auto Electric Supplies Ltd 2009.

6. Ownership of Goods

All goods supplied by Auto Electric Supplies Ltd shall remain the property of Auto Electric Supplies Ltd until such time as payment for the order has been received in full.

7. Bank Details

Account Name: Auto Electric Supplies Ltd
Account No: 00483279
Sort Code: 30-98-52
IBAN: GB81LOYD30985200483279
BIC: LOYDGB21529
Bank: Lloyds TSB

Company Reg. No: 5140360

VAT Reg. No: GB 771 3078 31

VEHICLE WIRING SERVICES

Specialist Historic and Vintage Vehicle Electricians

Bespoke wiring harnesses designed, manufactured, fitted and commissioned. Electrical reliability and authentic appearance for all types of historic, vintage, competition, touring or show vehicles, using suitable period or modern parts and materials. Fast turnaround and fixed price quotations, references available.

600 cars rewired over 10 years

Call Winston Teague 07971 415277 or David Aston 07968 225262

Email: vehiclewiring@googlemail.com

www.vehiclewiringservices.co.uk



ORDERING



www.autoelectricsupplies.co.uk

Order online using our easy to use secure web site. You will find up to the minute prices and products, be able to track your orders and view your order history. If you prefer, you can also use the web site to produce a printed order which you can then post or fax to us with your payment (see below).



01584 819552 (Mon - Fri: 9am - 5pm)

To enable us to process your order as quickly as possible, please be ready to quote the part numbers and quantities you require, and have your credit or debit card to hand. We accept MasterCard, Visa, Delta, Connect, Maestro and Solo.



01584 819355

Fax your completed order form and credit or debit card details to the above number any time. If you do not have an order form, please call us and we will fax you one by return.



Auto Electric Supplies Ltd, 11 Cross Street, Tenbury Wells, Worcestershire, WR15 8EF

Fill in the order form and send it together with credit or debit card details to the above address. If you would prefer to pay by cheque or postal order and would like to check that your order value is correct, please give us a call on 01584 819552. This helps to eliminate errors and ensures that your order can be despatched quickly. Please make cheques or postal orders payable to: 'Auto Electric Supplies Ltd'.

DELIVERY

UK Mainland

Standard Service

Up to £100 (exc. VAT): £3.75

Over £100 (exc. VAT): FREE

Goods are despatched as soon as possible subject to stock levels and cleared payment. Most packages are sent by post, but **heavier parcels will be despatched by Courier and will require a signature on delivery.** Most standard deliveries arrive within 2-3 days.

Next Working Day Service

NB. This service is only available for orders received before 1pm.

Up to 30kg: £6.55

Goods are despatched on the same day as the order is placed, subject to stock levels and cleared payment. Packages are sent either by Special Delivery or by Courier, and **will require a signature on delivery.** Although

the vast majority of packages will arrive the following day, please note that this service is not guaranteed. Any 'Next Day' orders received on a Friday will be delivered the next working day (i.e. there are no deliveries on Saturdays, Sundays or Bank Holidays).

Overseas, Scottish Isles, Channel Islands & N. Ireland

Postage will be charged at £1.50 + cost, subject to a minimum charge of £3.75. Goods are despatched as soon as possible subject to stock levels and cleared payment. The method chosen for despatch is dependent on the weight and/or value of the goods ordered, and will be the most cost effective available. Should you require a Courier service, or confirmation of delivery costs, please contact us on +44 (0)1584 819552, or info@autoelectricsupplies.co.uk.

PVC CABLE



STANDARD RANGE

General purpose low voltage cable suitable for use in automotive and marine applications in temperatures up to 70°C. Consists of conductors of stranded copper wire which are PVC insulated. Cable descriptions give the number and size of cable strands and the total cross-sectional area of conductor. For example, 14/0.30, 1.0mm² refers to 14 strands of 0.30mm dia. cable giving a total cable conductor area of 1.0mm².

Please note that there is a reduced choice of colours available for PVC cable, as motor vehicle manufacturers are now using thin wall cable as standard (see page 5).

Cable Type	Current (A)	Approx. Cable OD (mm)	m	30m	50m	Part No.
9/0.30	5.75	2.3	0.25	-	6.60	010101
14/0.30	8.75	2.6	0.28	-	8.21	010102
28/0.30	17.5	3.3	0.40	-	13.75	010103
44/0.30	27.5	3.7	0.56	-	21.90	010104
65/0.30	35.0	5.0	0.74	19.25	-	010105
84/0.30	42.0	5.7	0.95	26.75	-	010106
97/0.30	50.0	6.2	1.05	28.35	-	010107
120/0.30	60.0	7.0	1.20	32.40	-	010108
80/0.40	70.0	7.5	1.45	39.15	-	010109

USES:

010101 (0.65mm ²)	Side/tail lamps, indicators, etc.
010102 (1.0mm ²)	Side/tail lamps, indicators, fog lamps, general wiring.
010103 (2.0mm ²)	Head lamps, wipers, screen heaters, petrol pumps, etc.
010104 (3.0mm ²)	Charging circuits, main feeds.
010105 (4.5mm ²)	Heavy duty charge circuits, alternator feeds.
010106 (6.0mm ²)	Heavy duty charge circuits, alternator and battery feeds, etc.
010107 (7.0mm ²)	Heavy duty charge circuits, alternator and battery feeds, etc.
010108 (8.5mm ²)	Heavy duty charge circuits, alternator and battery feeds, etc.
010109 (10.0mm ²)	Heavy duty charge circuits, alternator and battery feeds, etc.

COLOURS AVAILABLE:

(When two colours are indicated, the first is the main colour and the second is the tracer colour).

010101

Black	Green	Orange	Red
Blue	Grey	Pink	White
Brown	Light Green	Purple	Yellow

010102

Black	Purple	Blue/Black	Brown/Red
Blue	Red	Blue/Brown	Brown/White
Brown	White	Blue/Green	Brown/Yellow
Green	Yellow	Blue/Red	Green/Black
Grey	Black/Blue	Blue/White	Green/Blue
Light Green	Black/Green	Blue/Yellow	Green/Brown
Orange	Black/Red	Brown/Black	Green/Purple
Pink	Black/Yellow	Brown/Green	Green/Red

010102 (contd)

Green/White	Red/Black	White/Blue	Yellow/Blue
Green/Yellow	Red/Green	White/Brown	Yellow/White
Light Green/Black	Red/White	White/Green	
Purple/Black	Red/Yellow	White/Red	
Purple/White	White/Black	Yellow/Black	

010103

Black	White	Brown/Blue	Red/Black
Blue	Yellow	Brown/Red	Red/Blue
Brown	Black/Green	Brown/White	Red/Brown
Green	Black/Red	Brown/Yellow	Red/White
Grey	Black/White	Green/Black	White/Red
Light Green	Blue/Green	Green/Red	Yellow/Black
Orange	Blue/Orange	Green/White	Yellow/Brown
Pink	Blue/Red	Green/Yellow	Yellow/Red
Purple	Blue/White	Purple/White	Yellow/White
Red	Blue/Yellow	Purple/Yellow	

010104

Black	Brown	Yellow	Brown/Yellow
Blue	Red		

010105

Black	Brown	Red	Yellow
-------	-------	-----	--------

010106

Black	Brown	Red	
-------	-------	-----	--

010107

Black	Brown	Red	
-------	-------	-----	--

010108

Black	Brown	Red	
-------	-------	-----	--

010109

Black	Red		
-------	-----	--	--



MULTICORE CABLE

Consists of PVC insulated single conductors sheathed in black PVC outer.

Cable	Capacity (A)	m	30m	Part No.
2 x 9/0.30	5.75	0.52	12.42	010201
2 x 14/0.30	8.75	0.55	13.10	010202
2 x 28/0.30	17.50	0.83	19.80	010203
3 x 14/0.30	8.75	0.80	19.27	010204
3 x 28/0.30	17.50	1.60	38.50	010205



TRAILER CABLE

Consists of a number of insulated single conductors sheathed in black PVC.

Cable	Capacity (A)	m	30m	Part No.
7 x 9/0.30	5.75	1.13	27.12	010301
6 x 14/0.30 + 1 x 28/0.30	6x8.75+17.5	1.55	37.28	010302

contd...



IGNITION LEAD (HT CABLE)

Copper conductors, black PVC insulated, 7mm diameter.

<i>m</i>	<i>30m</i>	<i>Part No.</i>
0.72	17.05	010401

As 010401, except 6mm diameter.

0.55	13.20	010403
------	-------	---------------



Black silicone outer, white silicone core, with tinned copper conductors (19 strands of 0.25mm). Temp. range of -30 to 155°C. Min. breakdown 35kV.

1.48	37.74	010402
------	-------	---------------



High performance PVC HT cable having a core of 28 strands of 0.3mm copper. The outer PVC sheath is 7mm OD and is yellow with two black stripes.

1.52	38.00	010404
------	-------	---------------



Ignition cable with a resistive core for use where suppression is required. Overall diameter 7mm. Colour black.

1.40	36.50	010405
------	-------	---------------

BATTERY/STARTER CABLE

There are two basic types of battery cable. There is semi-rigid (older type and fairly inflexible) and flexible (having 9 times as many finer strands and consequently being far more flexible). Available in either black or red.



Semi-Rigid

<i>Cable</i>	<i>Cable Size (mm²)</i>	<i>OD (mm)</i>	<i>Capacity (A)</i>	<i>m</i>	<i>10m</i>	<i>Part No.</i>
37/0.71	15	8.0	105	2.95	28.50	010501-*
37/0.90	25	9.7	170	4.18	39.93	010502-*
61/0.90	40	11.8	300	5.45	52.86	010503-*

* Specify colour: Red -R, Black -B



Flexible

<i>Cable</i>	<i>Cable Size (mm²)</i>	<i>OD (mm)</i>	<i>Capacity (A)</i>	<i>m</i>	<i>10m</i>	<i>Part No.</i>
206/0.30	16	8.2	110	2.71	25.00	010604-*
266/0.30	20	9.5	135	2.75	25.00	010601-*
196/0.40	25	9.8	170	3.52	32.45	010602-*
315/0.40	40	12.0	300	5.06	46.20	010603-*

* Specify colour: Red -R, Black -B

Please note: the flexible battery cable may be supplied with a different number of strands and strand sizes, but will be of the same cross-sectional area as that ordered.



EARTHING BRAID

Tinned copper earthing braid.

<i>Cable</i>	<i>Cable Size (mm²)</i>	<i>OD (mm)</i>	<i>Capacity (A)</i>	<i>m</i>	<i>10m</i>	<i>Part No.</i>
16x16/0.30	19	7.2	130	6.10	52.90	010801
16x32/0.30	37	11.1	260	10.40	93.88	010802



THIN WALL CABLE

Thin wall low voltage cable, suitable for use in automotive and marine applications. Consists of conductors of stranded copper wire which are hard grade PVC insulated. Compared to standard PVC cable, the reduced insulation thickness and higher current capacity greatly reduces weight and volume. For these reasons, this cable is today used in preference to standard PVC cable by vehicle manufacturers. Good resistance to petrol, diesel and abrasion. Suitable for use from -40°C to +105°C. Cable descriptions give number and size of cable strands and the total cross sectional area of the conductor.

<i>Cable Type</i>	<i>Conductor Size (mm²)</i>	<i>Current (A)</i>	<i>Cable O/D (mm)</i>	<i>m</i>	<i>30m</i>	<i>100m</i>	<i>Part No.</i>
16/0.20	0.5	11.0	1.6	0.21	-	9.25	010701
32/0.20	1.0	16.5	2.0	0.27	-	14.05	010702
28/0.30	2.0	25.0	2.7	0.36	-	24.60	010703
44/0.30	3.0	33.0	3.3	0.53	14.30	39.82	010704
56/0.30	4.0	39.0	3.7	0.72	16.72	49.50	010705
84/0.30	6.0	50.0	4.3	0.97	23.65	-	010706

COLOURS AVAILABLE:

(When two colours are indicated, the first is the main colour and the second is the tracer colour).

010701 (16/0.20 - 0.5mm² - 11.0A - cable OD 1.6mm)

Black	Green	Pink	White
Blue	Grey	Purple	Yellow
Brown	Orange	Red	

010702 (32/0.20 - 1.0mm² - 16.5A - cable OD 2.0mm)

Black	Black/Red	Green/Blue	Purple/Black
Blue	Black/White	Green/Brown	Purple/Brown
Brown	Black/Yellow	Green/Purple	Purple/Green
Green		Green/Red	Purple/Yellow
Grey	Blue/Black	Green/White	
Light Green	Blue/Orange	Green/Yellow	Red/Black
Orange	Blue/Pink		Red/Blue
Pink	Blue/Red	Grey/Black	Red/Green
Purple	Blue/White	Grey/Green	Red/White
Red	Blue/Yellow	Grey/Orange	Red/Yellow
White		Grey/Red	
Yellow	Brown/Black	Grey/White	White/Brown
	Brown/Green	Grey/Yellow	White/Orange
Black/Blue	Brown/Red		
Black/Green	Brown/White	Pink/Black	Yellow/Black
Black/Grey	Brown/Yellow	Pink/Red	Yellow/Brown
Black/Pink		Pink/White	Yellow/Red
Black/Purple	Green/Black	Pink/Yellow	Yellow/White

010703 (28/0.30 - 2.0mm² - 25.0A - cable OD 2.7mm)

Black	Purple	Blue/Yellow	Red/Black
Blue	Red		Red/Blue
Brown	White	Brown/Blue	
Green	Yellow	Brown/Green	White/Brown
Grey		Brown/Red	White/Orange
Orange	Blue/Red	Brown/White	
Pink	Blue/White		Yellow/White

010704 (44/0.30 - 3.0mm² - 33.0A - cable OD 3.3mm)

Black	Orange	Brown/Blue	White/Black
Blue	Purple	Brown/Green	White/Orange
Brown	Red	Brown/Red	White/Red
Green	White		
Grey	Yellow	Red/Yellow	

010705 (56/0.30 - 4.0mm² - 39.0A - cable OD 3.7mm)

Black	Brown	Red	Yellow
-------	-------	-----	--------

010706 (84/0.30 - 6.0mm² - 50.0A - cable OD 4.3mm)

Black	Brown	Red	Yellow
-------	-------	-----	--------

020101 (14/0.30 - 1.0mm² - 8.75A - cable OD 3.7mm)

Black	Black/White-H	Green/Purple	Yellow/Green
Blue	Black/Yellow-H	Green/Red	
Brown		Green/White	
Green	Blue/Red		
Purple	Blue/White	Purple/Black	
Red	Blue/Yellow		
White		White/Black	
Yellow			

020102 (28/0.30 - 2.0mm² - 17.5A - cable OD 4.2mm)

Black	Yellow	Brown/Blue	White/Black
Blue		Brown/White	White/Black-H
Brown	Blue/Red		
Green	Blue/White	Green/Black	
Purple	Blue/White-H		
Red	Blue/Yellow	Red/Black-H	
White			

020103 (44/0.30 - 3.0mm² - 27.5A - cable OD 4.7mm)

Black	Red	Brown/Blue	White/Red
Blue	White	Brown/White	
Brown	Yellow		Yellow/Black
Green		Red/Black-H	
Purple	Blue/White-H		

020105 (65/0.30 - 4.5mm² - 35A - cable OD 5.7mm)

Black	Brown	Red	Yellow
-------	-------	-----	--------

BRAIDED CABLE



GENERAL CABLE

Braided cable is an authentic replacement cable for older vehicles such as classic and vintage cars. Manufactured by braiding modern PVC cable and then lacquering. The cable therefore looks like the original but has the electrical and mechanical properties of modern cable.

Cable Type	Cable Size (mm ²)	Current (A)	<u>m</u>	<u>30m</u>	<u>50m</u>	Part No.
9/0.30	0.65	5.75	0.48	-	21.92	020104
14/0.30	1.0	8.75	0.56	-	25.12	020101
28/0.30	2.0	17.5	0.69	-	31.01	020102
44/0.30	3.0	27.5	0.91	-	41.16	020103
65/0.30	4.5	35.0	1.33	35.93	-	020105

The colours listed below are stock colours. Other colours are available, subject to a minimum quantity of 30m. When two colours are indicated, the first is the main colour and the second is the tracer colour. Herringbone pattern can also be supplied (shown as -H in the tables below).

020104 (9/0.30 - 0.65mm² - 5.75A - cable OD 3.0mm)

Black	Brown	Purple	White
Blue	Green	Red	Yellow



Main colour with tracer



Herringbone pattern (-H)



BRAIDED BATTERY/STARTER CABLE

As per general cable, braided battery cable is modern PVC semi-rigid battery cable that has been braided in black cotton and lacquered.

Cable	Cable Size (mm ²)	OD (mm)	Capacity (A)	m	10m	Part No.
37/0.71	15	8.0	105	4.17	37.95	020201
37/0.90	25	9.7	170	5.28	47.52	020202
61/0.90	40	11.8	300	6.55	58.91	020203



BRAIDED MULTICORE CABLE

PVC insulated single conductors sheathed in black PVC outer, braided in black cotton and lacquered.

Cable	Capacity (A)	m	10m	Part No.
2 x 9/0.30	5.75	1.64	13.11	020301
2 x 14/0.30	8.75	1.73	13.82	020302
2 x 28/0.30	17.50	1.95	15.58	020303
3 x 14/0.30	8.75	1.97	16.74	020304
3 x 28/0.30	17.50	2.34	18.74	020305



BRAIDED HT CABLE

Copper cored braided HT cable, PVC insulated, available in black, yellow/black or red/black (other colours can be made on request). 7mm OD.

* Specify colour: Black -B, Yellow/Black -Y/B, Red/Black -R/B, Red/Yellow -R/Y

m	25m	Part No.
1.79	40.35	020401 -*

NON-INSULATED TERMINALS & CONNECTORS

These terminals are normally tin-plated brass, but are sometimes plain brass. They can be either crimped or soldered to the cable - for relevant crimping tools, see page 87. A convenient way to insulate and tidy a non-insulated terminal is to stretch a neoprene sleeve over the crimped part of the terminal. These can be found on page 51.



Male Blade

Width (mm)	Cable (mm ²)	10	50	Part No.
4.8	0.3-0.8	0.61	2.44	030101
6.3	1.0-2.5	0.75	2.62	030102



Female Blade

Width (mm)	Cable (mm ²)	10	50	Part No.
2.8	0.3-0.8	0.53	2.10	030201
4.8	0.5-1.3	0.64	2.55	030202
6.3	0.5-1.5	0.59	2.35	030203
6.3	1.0-2.5	0.62	2.46	030204
6.3	2.5-6.0	0.65	2.57	030205
9.5	2.0-4.0	1.04	4.18	030206



Flag

Width (mm)	Cable (mm ²)	10	50	Part No.
6.3	1.0-2.5	0.86	3.41	030301



Piggy Back

Width (mm)	Cable (mm ²)	10	50	Part No.
6.3	0.5-1.5	1.25	4.99	030401
6.3	1.5-2.5	1.08	4.29	030402



Insulation Sleeves for Female Blades

Width (mm)	Colour	Type	10	50	Part No.
4.8	Transparent	Flexible	0.54	2.13	030501
6.3	Black	Rigid	0.91	3.63	030502
6.3	Transparent	Flexible	0.51	2.04	030503
9.5	Red	Flexible	1.49	5.93	030504
9.5	Transparent	Flexible	1.17	4.65	030506



Insulation Sleeves for Flags

Width (mm)	Material	10	50	Part No.
6.3	Clear vinyl PVC	0.49	1.97	030601



Bolt-On Blades and Adapters

Type	10	50	Part No.
6.3mm blade, 5.3mm mounting hole, flat	1.08	4.29	030103
6.3mm blade, 5.3mm mounting hole, 45°	1.05	4.20	030104
6.3mm blade, 5.3mm mounting hole, 90°	1.10	4.40	030105
9.5mm blade, 5.3mm mounting hole, flat	1.86	7.43	030106
Adapter - converts 1 male 6.3mm blade to 2	1.16	4.64	030107

Ring Terminals

Standard

Hole dia. (mm)	(Imp)	Cable (mm ²)	10	50	Part No.
3.2	4BA	0.5-1.5	0.52	2.06	030701
4.3	3BA	0.5-1.5	0.52	2.08	030702
5.3	2BA	0.5-1.5	0.52	2.08	030703
6.4	1/4"	0.5-1.5	0.67	2.67	030704
8.3	5/16"	0.5-1.5	0.69	2.75	030705
10.4	3/8"	0.5-1.5	0.78	3.11	030706



3.2	4BA	1.0-2.5	0.64	2.45	030707
4.3	3BA	1.0-2.5	0.66	2.65	030708
5.3	2BA	1.0-2.5	0.69	2.75	030709
6.4	1/4"	1.0-2.5	0.76	3.01	030710
8.3	5/16"	1.0-2.5	0.77	3.06	030711
10.4	3/8"	1.0-2.5	0.95	3.76	030712



4.3	3BA	2.5-6.0	0.89	3.56	030713
5.3	2BA	2.5-6.0	0.97	3.86	030714
6.4	1/4"	2.5-6.0	1.21	4.86	030715
8.3	5/16"	2.5-6.0	1.22	4.89	030716
10.4	3/8"	2.5-6.0	1.39	5.54	030717



Ring Terminals Heavy Duty

Hole dia. (mm)	(Imp)	Cable (mm ²)	10	50	Part No.
4.3	3BA	0.8-2.0	0.97	1.93	030806
5.4	2BA	0.8-2.0	1.10	2.20	030801
6.4	1/4"	0.8-4.0	1.46	2.92	030802
8.4	5/16"	0.8-4.0	1.57	3.13	030803
9.8	3/8"	up to 5.0	3.58	7.15	030804



Fork Terminals

Slot width (mm)	Cable (mm ²)	10	50	Part No.
4.3	0.5-1.5	0.56	2.24	030901
5.2	0.5-1.5	0.59	2.39	030902
3.8	1.0-2.5	0.73	2.89	030903
5.2	1.0-2.5	0.73	2.89	030904



NON-INSULATED TERMINAL KITS

See page 84.



STANDARD BULLETS AND CONNECTORS (4.7mm dia.)

Bullets

Suitable for crimping or soldering.

Max Cable (mm ²)	10	50	Part No.
0.65	1.60	6.50	031004
1.0	1.66	6.62	031001
2.0	1.02	4.07	031002
3.0	1.52	6.05	031003



Suitable for crimping.

Max Cable (mm ²)	10	50	Part No.
2.0	0.99	3.97	031005

Bullet Connectors

For use with all 4.7mm dia. bullets (above).

Type	Each	10	50	Part No.
Single	-	1.26	5.06	031101
Double (common)	-	1.34	5.38	031102
Triple (common)	1.56	12.51	-	031103
5-way	4.14	38.06	-	031104

HOLLOW BULLETS - OLD STYLE

Useful for connecting cables to lamps, etc. Strip cable, push into bullet and fold strands over. 4.6mm OD.

Max Cable (mm ²)	10	50	Part No.
2.0	1.10	4.40	031006



BULLET KIT

See page 84.



BULLET INSERTING/ CRIMPING TOOLS

See page 88.



BULLET SOCKET

Can be soldered or crimped. Accepts 4.7mm dia. bullets above. Comes complete with insulation sleeve.

10	50	Part No.
4.54	18.15	031201



JAPANESE BULLETS (3.9mm dia.)

Can be soldered or crimped. Suitable for cables 0.5 - 2.5mm².

Type	10	50	Part No.
Bullet	0.87	3.49	031301
Bullet insulator	0.53	2.11	031302
Socket	0.71	2.84	031303
Socket insulator	0.53	2.11	031304

INSULATED TERMINALS & CONNECTORS

STANDARD RANGE

Terminals are made from high conductivity copper strip, tinned for corrosion resistance. The colour-coded insulation sleeve extends beyond the crimping area to grip and support the cable insulation. Different colour insulation for different cable sizes.

Male Blade

Width (mm)	Cable (mm ²)	Colour	10	50	Part No.
6.3	0.5-1.5	Red	0.65	2.57	040102
6.3	1.5-3.0	Blue	0.67	2.69	040104
6.3	3.0-6.0	Yellow	0.80	3.19	040105

Female Blade

Width (mm)	Cable (mm ²)	Colour	10	50	Part No.
2.8	0.5-1.5	Red	0.59	2.35	040201
4.8	0.5-1.5	Red	0.80	3.22	040202
6.3	0.5-1.5	Red	0.74	2.96	040203
4.8	1.5-3.0	Blue	0.79	3.15	040204
6.3	1.5-3.0	Blue	0.77	3.08	040205
6.3	3.0-6.0	Yellow	0.89	3.54	040206
9.5	3.0-6.0	Yellow	1.53	6.09	040207



Female Blade - Fully Insulated

Width (mm)	Cable (mm ²)	Colour	10	50	Part No.
4.8	0.5-1.5	Red	0.95	3.78	040301
6.3	0.5-1.5	Red	0.96	3.81	040302
4.8	1.5-3.0	Blue	0.98	3.90	040303
6.3	1.5-3.0	Blue	0.97	3.87	040304
6.3	3.0-6.0	Yellow	1.35	5.42	040305
9.5	3.0-6.0	Yellow	2.45	9.80	040306



Piggy Back

Width (mm)	Cable (mm ²)	Colour	10	50	Part No.
6.3	0.5-1.5	Red	0.91	3.66	040401
6.3	1.5-3.0	Blue	0.98	3.89	040402
6.3	3.0-6.0	Yellow	1.51	6.02	040403

Ring Terminals

Hole dia. (mm)	(Imp)	Cable (mm ²)	Colour	10	50	Part No.
3.2	4BA	0.5-1.5	Red	0.46	1.86	040501
4.3	3BA	0.5-1.5	Red	0.48	1.95	040502
5.3	2BA	0.5-1.5	Red	0.52	2.07	040503
6.4	1/4"	0.5-1.5	Red	0.64	2.56	040504
8.4	5/16"	0.5-1.5	Red	0.68	2.72	040505
10.5	3/8"	0.5-1.5	Red	0.97	3.88	040506
12.0	1/2"	0.5-1.5	Red	1.07	4.27	040507
4.3	3BA	1.5-3.0	Blue	0.55	2.19	040508
5.3	2BA	1.5-3.0	Blue	0.55	2.19	040509
6.4	1/4"	1.5-3.0	Blue	0.68	2.72	040510
8.4	5/16"	1.5-3.0	Blue	0.70	2.81	040511
10.5	3/8"	1.5-3.0	Blue	0.89	3.55	040512
12.0	1/2"	1.5-3.0	Blue	1.31	5.21	040513
4.3	3BA	3.0-6.0	Yellow	0.76	3.04	040514
5.3	2BA	3.0-6.0	Yellow	0.84	3.34	040515
6.4	1/4"	3.0-6.0	Yellow	0.96	4.10	040516
8.4	5/16"	3.0-6.0	Yellow	1.18	4.71	040517
10.5	3/8"	3.0-6.0	Yellow	1.17	4.67	040518
12.0	1/2"	3.0-6.0	Yellow	1.66	6.66	040519



Bullets

Dia. (mm)	Cable (mm ²)	Colour	10	50	Part No.
4.0	0.5-1.5	Red	0.68	2.71	040601
4.0	1.5-3.0	Blue	0.87	3.49	040602
5.0	1.5-3.0	Blue	0.87	3.49	040603
5.0	3.0-6.0	Yellow	1.59	6.38	040604



Sockets

Dia. (mm)	Cable (mm ²)	Colour	10	50	Part No.
4.0	0.5-1.5	Red	0.80	3.22	040801
4.0	1.5-3.0	Blue	0.89	3.54	040802
5.0	1.5-3.0	Blue	0.89	3.54	040803
5.0	3.0-6.0	Yellow	1.59	6.38	040804



Butt Connectors

Cable (mm ²)	Colour	10	50	Part No.
0.5-1.5	Red	0.68	2.72	040901
1.5-3.0	Blue	0.71	2.84	040902
3.0-6.0	Yellow	1.28	5.08	040903



Fork Terminals

Slot Width (mm)	Cable (mm ²)	Colour	10	50	Part No.
4.3	0.5-1.5	Red	0.52	2.07	040701
5.3	0.5-1.5	Red	0.52	2.07	040702
6.4	0.5-1.5	Red	0.59	2.39	040703
4.3	1.5-3.0	Blue	0.49	1.98	040704
5.3	1.5-3.0	Blue	0.51	2.00	040705
6.4	1.5-3.0	Blue	0.68	2.71	040706
4.3	3.0-6.0	Yellow	0.70	2.82	040707
5.3	3.0-6.0	Yellow	0.75	2.97	040708
6.4	3.0-6.0	Yellow	1.01	4.03	040709



INSULATED TERMINAL KITS

See page 84.

HEATSHRINK INSULATED TERMINALS

These terminals offer superior performance over standard crimp terminals. After crimping, the hot-melt glue lined heatshrink sleeve is heated and shrunk down onto the cable. This increases the mechanical strength of the termination and its resistance to corrosion, as the melted glue effectively seals the joint.



Male Blade

Width (mm)	Cable (mm ²)	Colour	10	50	Part No.
6.3	0.5-1.5	Red	4.01	16.06	041101
6.3	1.5-3.0	Blue	4.01	16.06	041102

Female Blade - Fully Insulated

Width (mm)	Cable (mm ²)	Colour	10	50	Part No.
6.3	0.5-1.5	Red	4.57	18.26	041103
6.3	1.5-3.0	Blue	4.57	18.26	041104

contd...

HEATSHRINK INSULATED TERMINALS (contd)

Butt Connectors

Cable (mm ²)	Colour	10	50	Part No.
0.5-1.5	Red	3.52	14.08	041105
1.5-3.0	Blue	4.01	16.06	041106
3.0-6.0	Yellow	4.51	18.04	041107

Ring Terminals

Hole dia. (mm)	Cable (mm ²)	Colour	10	50	Part No.
4.0	0.5-1.5	Red	3.58	14.30	041108
5.0	0.5-1.5	Red	3.58	14.30	041109
6.0	0.5-1.5	Red	4.01	16.06	041110
4.0	1.5-3.0	Blue	3.58	14.30	041111
5.0	1.5-3.0	Blue	4.01	16.06	041112
6.0	1.5-3.0	Blue	4.24	16.94	041113
8.0	1.5-3.0	Blue	4.24	16.94	041114
5.0	3.0-6.0	Yellow	4.46	17.82	041116
6.0	3.0-6.0	Yellow	4.85	19.40	041117
8.0	3.0-6.0	Yellow	5.39	21.56	041118

SELF-STRIPPING CONNECTORS

A range of self-stripping connectors that provide a quick yet effective means of joining a second or tapping cable to an existing wire.

Main conductor size	Tapping cable	10	50	Part No.
9/0.30-28/0.30	9/0.30	0.88	2.75	041201
9/0.30-28/0.30	9/0.30-28/0.30	0.88	2.75	041202
44/0.30-65/0.30	44/0.30-65/0.30	1.79	7.15	041203

MULTIPLE CONNECTORS

MINI UNIVERSAL "MATE-N-LOK" CONNECTORS

Based on the "Mate-N-Lok" range, but much smaller. For low current applications where space is at a premium. These multiple connectors use 1mm diameter round pins locked into plastic housings. Available from 2 to 15 pins. Supplied as a pair of male/female housings that positively lock together, together with all terminals. Suitable for cables up to 1.2mm². Maximum current 5A per terminal.

No. of Terminals	Face Dim. (mm)	Each	10	50	Part No.
2	6 x 11	1.47	12.53	-	051401
3	6 x 15	1.80	15.33	-	051402
4	10 x 12	2.22	18.89	-	051403
6	14 x 12	3.21	27.30	-	051404
9	14 x 16	4.27	36.28	-	051405
12	18 x 16	5.24	44.51	-	051406
15	22 x 16	6.38	54.23	-	051407
Spare 1mm pins		-	1.64	6.56	051410
Spare 1mm receptacles		-	1.64	6.56	051411

UNIVERSAL "MATE-N-LOK" CONNECTORS

These multiple connectors use 2mm diameter round pins locked into plastic housings. Available from 2 to 15 pins. Supplied as a pair of male/female housings that positively lock together, together with all terminals. Suitable for cables up to 2mm². Maximum current 10A per terminal.

No. of Terminals	Face Dim. (mm)	Each	10	50	Part No.
2	8 x 14	1.38	11.69	-	051301
3	8 x 21	1.61	13.65	-	051302
6	21 x 14	2.51	21.32	-	051303
9	21 x 21	3.21	27.30	-	051304
12	21 x 27	3.98	33.85	-	051305
15	21 x 33	4.95	42.08	-	051306
Spare 2mm pins		-	1.33	5.61	051310
Spare 2mm receptacles		-	1.33	5.61	051311

3.5mm "MATE-N-LOK" CONNECTORS

These multiple connectors use 3.5mm diameter round pins, locked into plastic housings. Available from 2 to 9 pins. Supplied as a pair of male/female housings that positively lock together, together with all terminals. Suitable for cables between 2.0mm² and 5.0mm². Maximum current approximately 20A per terminal.

No. of Terminals	Face Dim. (mm)	Each	10	Part No.
2	7 x 14	1.49	13.37	055001
3	7 x 20	1.76	15.84	055002
4	13 x 20	2.25	20.30	055003
9	20 x 20	4.24	38.06	055004

6.3mm BLADE CONNECTORS

These multiple connectors use 6.3mm blade terminals locked into plastic housings. They are available from 1 to 8 pins and are supplied as a pair of male and female quick release nylon connector housings. The terminals for the housings are available for two different wire sizes and should be purchased separately. Terminals are secured by crimping or soldering.

Housings

No. of Terminals	Each	10	Part No.
1	0.31	2.69	050101
2	0.42	3.60	050102
2 (T-shape)	0.47	4.10	050107
3	0.49	4.31	050103
4	0.58	5.05	050104
6	0.66	5.75	050105
8	0.82	7.21	050106
11	2.00	17.38	050108

Terminals

Type	Cable Size (mm ²)	Each	10	Part No.
Male	1.0-2.5	0.06	0.39	050201
Female	1.0-2.5	0.06	0.39	050203
Male	2.5-6.0	0.11	0.85	050202
Female	2.5-6.0	0.11	0.85	050204



WATER-PROOF CONNECTORS

Econoseal

Water-proof connectors. Suitable for cables up to 1mm². Supplied with all seals and terminals.

Type	Face Dim. (mm)	Each	10	Part No.
2-way male	18 x 13	1.83	16.43	051201
2-way female	21 x 18	1.83	16.43	051202
3-way male	23 x 13	2.18	19.60	051203
3-way female	26 x 18	1.91	17.23	051204



1.5mm Blade - Superseal

Water-proof multiple connectors, 1 to 6 way. Supplied in pairs with all seals and terminals. Terminals can take cables up to 1.5mm². Current rating up to 14A per terminal.

Terminals	Housing Dimensions	Each	10	100	Part No.
1	54 x 14 x 14	2.34	19.92	-	050601
2	54 x 19 x 14	3.09	26.28	-	050602
3	54 x 25 x 14	4.30	36.56	-	050603
4	54 x 32 x 14	5.07	43.11	-	050604
5	54 x 38 x 14	6.52	55.45	-	050605
6	54 x 44 x 14	7.49	63.68	-	050606

Spare male terminals	-	1.35	11.51	050607
Spare female terminals	-	1.74	14.77	050608



2.8mm Blade - Superseal

Water-proof multiple connectors, 1 to 3 way. Supplied in pairs with all seals and terminals. Terminals can take cables up to 2mm².

Terminals	Housing Dimensions	Each	10	Part No.
1	63 x 16 x 15	3.52	29.92	050701
2	63 x 23 x 15	4.25	36.13	050702
3	66 x 30 x 15	7.02	59.65	050703



Circular Rubber Connectors

Rubber connectors suitable for harsh environments. The one-piece moulded halves have wire seals offering high resistance to fluid ingress. Supplied in kit form, with both mating half connectors and all terminals. Current rating 8A.

Way	Housing Diameter (mm)	Each	Part No.
2	16	5.87	051001
3	18	6.27	051002
4	21	6.73	051003
5	23	7.02	051004
6	25	7.51	051005



Junior Power Timer Connectors

Female housings are available in 5 different configurations with either 2, 3, 4, 5 or 6 terminals. Only one male housing is stocked, which has 2 terminals. Terminals for the housings should be purchased separately and are available for two different cable sizes, together with wire seals which push into the back of the connectors (also available for two different size cables). Rubber boots are available to seal the back of the 2 and 3-way connectors.

No. of Terminals	Type	Each	10	Part No.
2	Female Housing	1.10	9.35	051501
3	Female Housing	1.59	13.56	051502
4	Female Housing	2.75	23.38	051503
5	Female Housing	5.60	50.40	051504
6	Female Housing	5.78	51.02	051505
2	Male Housing	2.20	18.70	051507



Female terminals for 0.5-1.0mm ² cable	0.33	2.75	051601
Male terminals for 0.5-1.0mm ² cable	0.33	2.75	051603
Female terminals for 1.5-2.5mm ² cable	0.33	2.75	051602
Male terminals for 1.5-2.5mm ² cable	0.33	2.75	051604



Wire seal for 1.2-2.1mm ² cable (blue)	0.18	1.58	051801
Wire seal for 2.2-3.0mm ² cable (white)	0.19	1.68	051802
Blanking wire seal (brown)	0.22	1.98	051803



7-POLE CYLINDRICAL CABLE CONNECTOR Each Part No.

Comprises of moulded plug and socket and rubber covers. Supplied with terminals. 3mm pins/sockets. Overall joined connector size approx. 60 x 25mm (without rubber covers). Can accept 7 cables up to 2mm² each.

4.35 **051901**



3-POLE PLUG & SOCKET

3-pin black thermoplastic plug/socket having two larger pins and one small pin. All terminals are nickel plated and are rated at 2 x 25A and 1 x 5A respectively. Plug diameter 30mm and overall length 70mm. Comes with plastic dust cap for when not in use. Socket has mounting flange and spring loaded cap to prevent water ingress when not in use.

Type	Each	Part No.
Socket	5.10	052001
Plug	5.10	052002



LARGE CABLE CONNECTORS

Single and double pole large cable connectors, having a current capacity of 75A. Supplied in pairs with all terminals (8mm blades) and terminal locking tabs.

Terminals	Cable Size (mm ²)	Each	10	Part No.
1	4-6	5.46	46.44	050801
2	4-6	8.55	72.70	050802
1	6-10	5.46	46.44	050803
2	6-10	8.55	72.70	050804



LUCAS/BOSCH ALTERNATOR PLUG

Black plastic plug servicing most Bosch and Lucas alternators. Contains 2 x 9.5mm and 1 x 6.3mm female blade connectors.

Each	Part No.
3.08	050901



HEAD LAMP CONNECTING SOCKETS

For connecting to P43t and P45t bulbs and sealed beam lamps. Supplied with terminals.

Type	Each	Part No.
Straight terminals	1.41	050501
90° terminals (wire exits from side of socket)	1.46	050502



CONNECTORS - GENERAL

Blade Terminal Connectors

Insulated connector to join two or three 6.3mm female blade terminals together.

Type	Each	10	Part No.
Connector to join two blade terminals	0.28	2.34	051101
Strip of 12 of above	1.79	15.25	051102
Connector to join three blade terminals	0.48	4.11	051103

Standard PVC 12-Way Terminal Blocks

Maximum cable size (mm ²)	Each	10	Part No.
3.0	0.42	3.55	051104
4.0	0.44	3.74	051105
6.0	0.69	5.90	051106



Plug Together

Pair of male/female 12-way terminal blocks that can be plugged together and easily cut down to smaller units. Pin size 2.6mm. Maximum cable 44/0.30 (3mm²).

Each	Part No.
3.96	051107



Terminal Blocks - Screw/Screw

Terminal blocks with screw/screw terminations. Made from black filled polyester with chassis fixing holes. Screws are 4BA.

Type	Each	Part No.
4-way	3.32	051108
12-way	6.49	051109



Terminal Block - 7 Way

Terminal block with 7 common screw connections. Single mounting hole.

3.75	051110
------	---------------

IGNITION RELATED ITEMS



SPARK PLUG TERMINALS

Solder Type

Blade type spark plug terminals.

Each	10	Part No.
1.04	8.88	060103



Crimp Type

Plated Steel. Suitable for 7mm ignition cable.

Item	Suitable Cover	Each	10	Part No.
Straight	060201	0.15	1.28	060101
90°	060202	0.21	1.65	060102



SPARK PLUG TERMINAL COVERS

Black hypalon. Suitable for 7mm ignition cable.

Item	Each	10	Part No.
Straight	0.49	3.96	060201
90°	0.77	6.29	060202



DISTRIBUTOR/COIL ACORNS

Item

Distributor cap acorn (short)
Coil acorn (long)
Brass washers for above

Each	10	Part No.
0.49	4.21	060801
0.99	8.41	060802
0.20	1.68	060803



PLUG CAPS

Non-Suppressed

Black phenolic straight plug cap, 70mm long. **Each** 1.32 **10** 11.55 **Part No.** 060501

Suppressed

Black phenolic spark plug caps with a 10K ohm carbon suppressor.

Item	Each	10	Part No.
Straight (57mm long)	1.21	10.29	060601
90°	1.17	9.89	060602
In-line suppressor (screw thread at each end)	1.04	8.89	060603



DISTRIBUTOR/COIL TERMINALS

Brass. Suitable for 7mm ignition cable.

Item	Suitable Cover	Each	10	Part No.
Straight	060401, 060402, 060403, 060405	0.20	1.75	060301
90°	060404	0.28	2.34	060302
Screw on		0.22	1.81	060303



DISTRIBUTOR/COIL TERMINAL COVERS

Black PVC. Suitable for 7mm ignition cable.

Item	Application	Int. Dia. (mm)	Each	10	Part No.
Straight	Dist	15	0.15	1.32	060401
Straight	Coil	16	0.31	2.63	060402
Straight	Coil	19	0.15	1.32	060403
90°	Dist/Coil	14	0.32	2.72	060404
Straight	Dist	14	0.22	1.93	060405



HT TERMINAL KITS - see page 84.

IGNITION LEAD MARKERS

Heat-shrinkable ignition lead markers. White with black text. Shrink from 12mm dia. to a minimum of 4mm dia. when heated using a hot air gun. Sold in bags of 100, each bag having 10 of 0, 1, 2, 3, 4, 5, 6, 7, 8 & 9.

No's 1 to 4, one of each. **Each** 0.44 **Part No.** 060902

No's 1 to 6, one of each. **Each** 0.66 **Part No.** 060903



IGNITION LEAD SEPARATORS

Black nylon clip-on ignition lead separators. Available in two, three or four lead versions.

Type	Each	Part No.
Two lead separator	0.17	061001
Three lead separator	0.22	061002
Four lead separator	0.28	061003



HT TESTER

Use this product to see whether you have a spark at the spark plug. Remove plug cap from spark plug, push tester onto the top of the spark plug and then reconnect plug cap to top of tester. The tester will flash each time there is a spark.

Each 2.19 **Part No.** 061201



IGNITION COILS

Standard Terminal

Metal cans with bakelite or polyester (060705) insulation. Connections via M5 studs or spade terminals. Coils are supplied with bolt-on 6.3mm male blades which can easily be removed to leave the studs available. HT connection via push-in terminal (060301, 060302 or 060303).

Type	Each	Part No.
12V standard coil	13.26	060701
12V ballast resistor coil (for use with 060703)	13.26	060702
6V standard coil	14.30	060704
12V electronic coil (for transistorised ign. systems)	14.30	060705

Ballast resistor 1.6 ohms (for use with 060702) **Each** 4.38 **Part No.** 060703



Acorn Terminal

Coils with older style screw terminal HT connection. Low tension connections are 5mm studs which come complete with spade terminal connections (removable). Available as either 6V or 12V.

Type	Each	Part No.
12V	15.62	060706
6V	15.62	060707



Lucas

Lucas DLB101 - standard 12V coil. **Each** 17.50 **Part No.** 060710

Lucas DLB102 - standard 12V coil for use with 1.6 ohm ballast resistor (part no. 060703). **Each** 18.60 **Part No.** 060711

Lucas DLB105 - high performance 12V coil. **Each** 21.50 **Part No.** 060712

Lucas DLB110 - high performance 12V coil for use with 1.6 ohm ballast resistor (part no. 060703). **Each** 25.90 **Part No.** 060713





LUCAS CONDENSERS

Type	Each	Part No.
Lucas DCB104C	3.87	061101
Lucas DCB121C	10.50	061102
Lucas DCB203C	4.62	061103
Lucas DCB703C	4.07	061104
Lucas DCB752C	3.19	061105
Lucas DCB101C	3.03	061106
Lucas DCB221C	4.35	061107
Lucas DCB112C	4.03	061108

BATTERY RELATED ITEMS



BATTERY POST CLEANING BRUSH Brush for cleaning standard battery posts and terminals.	Each	Part No.
	10.89	072001
ANTI-CORROSIVE COMPOUND An anti-corrosive compound which neutralises corrosion and inhibits deterioration of terminals and metal parts on or near lead acid batteries.	Each	Part No.
	3.10	072002



BATTERY REMOVAL/CARRYING STRAP Acid resistant belting, 25mm wide, with quick fix grips to fit terminal posts, and hooks for flat battery posts.	Each	Part No.
	10.78	072003



BATTERY POST WASHERS Battery post washers help to prevent corrosion, ensuring good electrical contact and inhibiting deterioration of posts on lead acid batteries. Supplied in pairs.	Pair	Part No.
	2.20	072005



BATTERY BOX Moulded in grey plastic, to accommodate most sizes of battery. 370mm long x 170mm wide x 270mm high.	Each	Part No.
	38.88	072006



BATTERY CLAMPS Made from tinned brass.			
Screw Type			
<i>Pole Type</i>	<i>Cable (mm²)</i>	Each	Part No.
-ve	Up to 40	1.82	070101
+ve	Up to 40	1.82	070102
-ve	Up to 60	2.04	070103
+ve	Up to 60	2.04	070104



Solder Type			
<i>Pole Type</i>	<i>Cable (mm²)</i>	Each	Part No.
-ve	Up to 25	2.90	070205
+ve	Up to 25	2.90	070206
-ve	Up to 40	2.90	070201
+ve	Up to 40	2.90	070202



Stud Type			
<i>Pole Type</i>	<i>Stud Size (mm dia.)</i>	Each	Part No.
-ve	8	2.18	070301
+ve	8	2.18	070302



End Feed Suitable for crimping or soldering. These are universal and will fit both positive and negative battery posts.			
<i>Max. cable size (mm²)</i>		Each	Part No.
20		1.93	072707
25		1.93	072708



BATTERY CLAMP NUT/BOLT

Replacement nut and bolt for battery clamps. 5/16" Whitworth thread. Electro-tin plated. 38mm long.

Each *Part No.*
0.33 **073003**



BATTERY CLAMP COVERS

For Screw and Solder Type Clamps

PVC battery terminal covers for use with screw and solder type battery terminals. Available in red or black.

Cable Entry *Colour*

	<i>Each</i>	<i>Part No.</i>
LH	0.79	070501
LH	0.79	070502
RH	0.79	070503
RH	0.79	070504



For End Feed Type Clamps

For use with end feed type battery clamps (072707 & 072708).

Colour

	<i>Each</i>	<i>Part No.</i>
Red	0.79	070505
Black	0.79	070506



For Stud Type Clamps

For use with stud type battery clamps (070301 & 070302).

Colour

	<i>Each</i>	<i>Part No.</i>
Blue	1.06	070507
Red	1.06	070508



BATTERY CABLE CONNECTORS

These connectors are used to join battery cables. Heavy brass body with four grub screws and heat shrinkable sleeving.

Max Cable Size (mm²)

	<i>Each</i>	<i>Part No.</i>
25	5.17	070601
40	5.81	070602



BATTERY LEAD JUNCTION BOX

A plastic junction box with a hinged lid capable of 300A continuous. It has 2 x 8mm studs so that many cables can be joined, and a fixing hole enabling it to be surface mounted.

Each *Part No.*
7.92 **070701**



BATTERY CABLE TERMINALS

Open End

Tinned copper terminals suitable for crimping or soldering.

<i>Max Cable (mm²)*</i>	<i>Stud Hole Size (mm)</i>	<i>Each</i>	<i>10</i>	<i>Part No.</i>
10	6	0.40	3.37	070901
10	8	0.43	3.65	070902
10	10	0.46	3.93	070903
16	6	0.52	4.40	070904
16	8	0.54	4.62	070905
16	10	0.57	4.86	070906
25	6	0.59	5.05	070907
25	8	0.62	5.24	070908
25	10	0.64	5.42	070909
40	6	0.71	6.08	070910
40	8	0.75	6.36	070911
40	10	0.78	6.64	070912
40	12	0.81	6.92	070913

Closed End

Straight

Closed end tinned copper terminals with inspection hole. Suitable for crimping or soldering.

<i>Max Cable (mm²)*</i>	<i>Stud Hole Size (mm)</i>	<i>Each</i>	<i>10</i>	<i>Part No.</i>
6	6	0.34	2.90	071001
6	8	0.34	2.90	071002
10	6	0.42	3.55	071003
10	8	0.42	3.55	071004
10	10	0.43	3.65	071005
10	12	0.43	3.65	071006
16	6	0.47	4.05	071007
16	8	0.51	4.30	071008
16	10	0.51	4.30	071009
16	12	0.53	4.49	071010
25	6	0.54	4.59	071011
25	8	0.56	4.77	071012
25	10	0.58	4.96	071013
25	12	0.60	5.14	071014
40	6	0.64	5.42	071015
40	8	0.67	5.71	071016
40	10	0.70	5.98	071017
40	12	0.75	6.36	071018
50	6	0.86	7.29	071019
50	8	0.89	7.58	071020
50	10	0.91	7.77	071021
50	12	0.94	7.95	071022

*NB: the figure given in mm² is the cross sectional area of the conductor of the cable, not its diameter. Please refer to page 4 for cable OD information.



BATTERY CABLE TERMINALS (contd)

Closed End Right Angled

Tinned copper terminals suitable for crimping or soldering.

Max Cable (mm ²)*	Stud Hole Size (mm)	Each	10	Part No.
16	8	0.73	6.17	071104
25	8	0.86	7.29	071101
40	8	1.03	8.79	071105
50	8	1.28	10.85	071102



Flag Terminals

Terminals suitable for crimping or soldering.

Max Cable (mm ²)*	Stud Hole Size (mm)	Each	10	Part No.
50	9.5	0.64	5.42	072202
70	13.5	0.66	5.61	072203

* NB: the figures given in mm² are the cross sectional area of the suitable cable, not its diameter. Please refer to page 4 for cable OD information.



TERMINAL COVERS

Push-on black covers for terminals to insulate open or closed end battery terminals. 070801-03 are rubber, 070804 are nylon.

Int. Sleeve Dia. (mm)	Int. Cap Dia. (mm)	Each	10	Part No.
6	11	0.38	3.22	070801
7.5	15	0.39	3.30	070802
9	15	0.44	3.77	070803
17	27	0.75	6.38	070804



BUTT SPLICES

Crimp butt splices for cable joining. Made from tinned copper.

Max. cable (mm ²)	Each	10	Part No.
2.5	0.13	1.12	072607
4	0.18	1.50	072608
6	0.28	2.34	072601
10	0.36	3.09	072602
16	0.37	3.19	072603
25	0.49	4.21	072604
35	0.64	5.42	072605
50	0.67	5.71	072606



PREFORMED BATTERY CABLES

Battery Terminal - Ring Terminal

Preformed battery cables made from 266/0.30mm, 20mm² battery cable, 135A capacity, 8mm ring terminal. Universal battery terminal to fit either positive or negative terminal.

Length (mm)	Each	Part No.
225	6.78	072101
300	7.02	072102
450	7.57	072103
600	8.58	072104



Ring Terminal - Ring Terminal

Preformed battery cables made from 37/0.90, 25mm² black cable, with 170A capacity. At each end of the cable is an 8mm ring terminal.

Length (mm)	Each	Part No.
300	3.98	071901
450	4.85	071902
600	5.72	071903



BONDING STRAPS

Universal flat bonding straps. Tinned copper, 100A, 24mm wide, 10mm diameter holes.

Length (mm)	Each	Part No.
150	2.22	071401
300	2.88	071402
450	3.54	071403



EARTH STRAPS

Tinned copper, 110A, 10mm diameter hole in end of braid. Fit negative battery terminal.

Length (mm)	Each	Part No.
150	3.08	071301
300	4.27	071302
450	5.45	071303



BATTERY HOLD DOWN CLAMP

Battery hold down clamp, punched angle bracket 348mm and two threaded 385mm J-bolts with wing nuts. Tin plated. Adjusts to fit all popular sizes of battery.

Each	Part No.
2.92	072401



POWER CONNECTORS & HANDLES

2 pole connectors used to safely and easily connect/disconnect battery/welding leads. 2 connectors are required. For example: one mounted on the vehicle, the other on the end of the jump start battery leads. Handles are available for use with the 175A and 350A rated connectors.

Current Rating (A)	Max Cable (mm ²)	Each	Part No.
50	6	6.55	071501
175	50	9.88	071502
350	70	16.10	071503



Handle

Type	Each	Part No.
175A	6.66	071601
350A	6.66	071602

BATTERY ISOLATOR SWITCHES

Battery isolator switches enable battery supply to be cut instantly. Vital in an emergency and also very useful during vehicle storage to ensure electrical isolation.

Type

Isolator switch with removable key. 100A@24V, 500A for 5 sec. M8 studs. Spare key and rubber protector cap available separately. Two fixing holes 45mm apart.

Each *Part No.*
6.82 **071716**

Spare key for item 071716.

1.78 **071710**

Rubber protector cap for item 071716.

0.83 **071703**

Battery isolator switch with removable key and splash proof cover and independent ignition switch to prevent engine run on in an emergency. Supplied with 3 Ohm resistor to suppress alternator surge spikes from damaging the electrical system when isolator switch is operated. 100A@24V, 500V for 5 secs. M10 studs. Supplied with wiring diagram. Connection details - see page 91.

21.08 **071704**

Spare key for item 071704.

1.65 **071702**

Battery isolator with removable key in the 'on' or 'off' position. 100A@24V, 500V for 5 secs. M10 studs. Comes with 2 keys. Requires 23mm panel hole.

26.89 **071705**

Lucas style SSB106 battery isolator with fixed black handle and metal case. 120A@12V. M10 studs. Requires 19mm panel hole.

13.20 **071707**

Lucas SSB106 battery isolator. Has 150A continuous current capacity and 1500A intermittent capacity. 3/8" Whitworth studs. Requires 19.5mm mounting hole.

39.05 **071717**

Type

High quality, metal cased isolator switch. Waterproof to SAE J1171. 150A @ 24V continuous. 1000A @ 24V for 5 seconds. Non removable plastic key. Two fixing holes 45mm apart.

Each *Part No.*
32.73 **071708**

Lucas SSB103 battery isolator switch. *Limited stock available.*

53.90 **071709**

Replica version of above switch (looks virtually identical).

32.50 **071718**

Quick Disconnect

Battery terminals with a green plastic tightening wheel for quick disconnection. Ideal for isolating battery. Available with or without terminal bridging fuse holder (for radio, alarm and clock feeds). Fits negative battery terminal.

Type

Without fuse
With fuse

Each *Part No.*
7.26 **070401**
10.85 **070402**

Marine battery isolator with removable key and splash proof cover. Rated at 100A@24V. M10 studs. Requires 22.5mm fixing hole.

13.99 **071711**

Spare key for item 071711.

1.91 **071712**

Marine battery isolator and change over switch. Can be used to select between batteries one, two, both or off. Rated at 175A@12V and 300A for 5 seconds. M10 studs. 138mm x 138mm x 70mm.

22.86 **071713**

STARTER SWITCHES/SOLENOIDS

Type

Lucas replacement starter solenoid. 12V with manual rubber button. 8mm stud terminals.



Each *Part No.*
21.45 **071801**

Lucas replacement basic 12V solenoid. 8mm stud terminals.



10.89 **071802**

6V starter solenoid. Battery cable connection via 2 x M8 Studs. Switch connection via M5 stud. Supplied mounted to bracket.



21.12 **071807**

Floor mounted foot operated starter switch. 8mm stud terminals.



22.23 **071803**

Lucas SRB312 starter switch. 2 x 5/16" stud terminals. Needs 10mm mounting hole.



24.75 **071804**

Lucas starter switch SRB311 (ST18/1). 2.5" dia. black fixing plate with aluminium knob. 2 x 5/16" stud terminals.



38.76 **071805**

SWITCHES

TOGGLE SWITCHES

Metal

Metal toggle switches with plated levers. All have 6.3mm blade terminals and require a 13mm panel hole. Current ratings in the table below are at 12V. (On) = momentarily on.

Single Pole

Type	Positions	Terminals	Current (A)	Each	Part No.
On/Off	2	2	16	3.42	080101
Off/(On)	2	2	16	3.85	080107
On/On	2	3	16	3.63	080102
On/Off/On	3	3	16	3.63	080103
On/Off/(On)	3	3	16	4.05	080104
(On)/Off/(On)	3	3	16	4.05	080106
Off/OnA/OnA+B	3	3	20	7.44	080105



Metal (contd)

Double Pole

Type	Positions	Terminals	Current (A)	Each	Part No.
On/Off	2	4	16	4.85	080201
On/On	2	6	16	5.26	080202
On/Off/On	3	6	16	5.39	080203



Rubber cap for above switches. Fits all metal toggle switches except part no. 080105.

1.16 **080301**



Splash Proof

Single pole switches with rubber sealing gaiters over nickel plated brass levers. 6.3mm blade terminals. Require 13mm panel hole. 10A@12V. (On) = momentarily on.

Type	Positions	Terminals	Each	Part No.
On/Off	2	2	7.26	081801
On/Off/On	3	3	8.27	081802
On/Off/(On)	3	3	8.07	081803
(On)/Off/(On)	3	3	8.07	081804



Lucas

Original Lucas items (except 081605 which is a good quality replica of SPB200). Connections via 6.3mm blade terminals. All require 13mm panel hole. Fit panels up to 3mm thick.

Type	Lucas Part No.	Positions	Current (A)	Each	Part No.
On/Off (repro.)	-	2	5	5.50	081605
On/Off	SPB200	2	5	10.95	081601
On/Off/On (ind.)	31743	3	10	15.18	081602
On/On	31780	2	10	15.05	081603
Off/OnA/On A+B	31788	3	10	17.16	081604



LED Toggle Switches

Nickel plated on/off single pole toggle switches, with 12/24V LED indicator at end of toggle. 6.3mm blade terminals, 13mm panel hole. 10A @ 28V dc.

Type	Each	Part No.
Blue LED	4.25	082201
Green LED	4.25	082202
Red LED	4.25	082203
Amber LED	4.25	082204



Metal/Plastic

Toggle switches with turned aluminium levers. Single pole. Require 13mm panel hole. Maximum panel thickness 2.5mm. On/off switch is round, on/off/on is teardrop shaped.

Type	Positions	Terminals	Current (A)	Each	Part No.
On/Off	2	2	6	4.51	081701
On/Off/On	3	3	6	3.54	081702



contd...



TOGGLE SWITCHES (contd)

Miniature

Toggle switches with metal lever, requiring 6mm panel hole. Solder connections. 6A @ 12V, 3A @ 24V.

Type	Positions	Terminals	Each	Part No.
On/Off	2	2	2.25	082301
On/On	2	3	2.25	082302
On/Off/On	3	3	2.25	082303



Plastic

Toggle switches with black plastic levers. 6.3mm blade terminals. Require 13mm panel hole. All single pole. Current ratings below are at 12V. (On) = momentarily on.

Type	Positions	Terminals	Current (A)	Each	Part No.
On/Off	2	2	10	0.66	080401
(On)/Off	2	2	16	0.84	080402
On/On	2	3	5	0.84	080403
On/Off/On	3	3	10	2.77	080404



Long Lever Plastic

On/Off switch with long black lever with two 6.3mm blade terminals. Requires 12.5mm panel hole. 10A@12V. 75mm long toggle.

Each	Part No.
2.15	080406

Off/(On) - momentarily on. 12V. 16A. 55mm long toggle.

Each	Part No.
2.15	080407



Illuminated Plastic

On/Off toggle switches which illuminate when switched on. 10A@12V. Require 13mm panel hole. 2 x 6.3mm blade terminals. Available in blue, green or red.

* Specify colour: Blue -U, Green -G, Red -R

Each	Part No.
1.44	080501-*



SWITCH PANELS

All switch panels have 13mm mounting holes.

Black Coated Steel

Type

Single
Double

Each	Part No.
0.79	080601
1.05	080602



Black Plastic

Type

1 hole
2 holes
3 holes
4 holes

Each	Part No.
0.55	080603
0.72	080604
0.88	080605
1.10	080606



TOGGLE SWITCH FASCIA

Simply place under the nut that secures the switch. A tag on the fascia ensures it is the correct way up. Chromed steel.

Each	Part No.
0.57	082001



TOGGLE SWITCH SAFETY GUARD

Moulded plastic, spring loaded to cover toggle. Prevents accidental switch use. Fits most 13mm diameter toggle switches. Available in four colours.

Type

Red
Blue
Green
Yellow

Each	Part No.
2.64	082002
2.64	082003
2.64	082004
2.64	082005



PUSH/PULL SWITCHES

Type

Simple push/pull switch. On/off. Black knob. 2 x screw terminals. 25A@12V. 8mm fixing hole. Maximum panel thickness 2.5mm.

Each	Part No.
1.43	080701



As above except maximum panel thickness 12mm.

Each	Part No.
1.54	080707



3 position push/pull heavy duty switch. Off/On A/On A+B. Suitable for side/headlamps. Screw terminals. 10A@12V. 13mm fixing hole.

Each	Part No.
7.35	080702



Illuminated on/off push/pull switch. Only illuminated when switched on. 6.3 mm blade terminals. 10A@12V. 13mm fixing hole. Available with green, red, white or amber lens.

Each	Part No.
7.25	080703-*

* Specify colour: Green -G, Red -R, White -W, Amber -A



Replica Lucas SPB104. Push/pull on/off switch. 2 screw terminals. Requires 10mm panel hole. Maximum panel thickness 13mm.

Each	Part No.
11.50	080708

PUSH BUTTON SWITCHES

Type



Black knob, metal housing. One screw terminal. Pressing button connects terminal to metal housing. 12.5mm fixing hole.

Each Part No.
12.05 **080810**



Black knob, plastic housing. Two screw terminals. 15.5mm fixing hole. 7A@12V.

3.96 **080812**



Push/push button switch. Metal button, metal housing. When pushed on, it remains on until pushed again. 13mm panel hole. 2 x 6.3mm blade terminals. 6A@12V DC.

8.73 **080813**



Stainless steel button and nickel plated brass body. Screw terminals. Requires 19mm panel hole. 6A @ 12V DC.

3.75 **080814**



Red plastic button and aluminium body. 2 x 6.3mm blade terminals. Requires 22mm panel hole.

5.80 **080815**



Chrome plated steel body with recessed red button. 2 x screw connections. Requires 22mm panel hole.

9.19 **080816**



Black knob, plastic housing. 12.5A@12V. 2 screw terminals. 22 mm fixing hole.

3.65 **080801**



Black knob, metal housing. 10A@12V. 2 screw terminals. 22 mm fixing hole.

4.55 **080802**



Bosch polished aluminium switch with black button. Surface mounted. Very similar to vintage Bosch switches, except cover clips on rather than screws on. 15A@12V. External diameter 35mm. 2 x screw terminals.

21.50 **080804**



Lucas SPB160 black horn push switch. Has screw terminals and two mounting ears with mounting hole centres 42.5mm apart. 5A@12V.

10.40 **080808**

Type



Water-proof push button switch. Has black rubber cover and requires 22.5mm panel hole. Maximum panel thickness 5mm. 2 x screw terminals. 16A@12V.

Each Part No.
4.92 **080806**



Lucas SPB106 panel switch. Chrome plated body with black push button. Requires 20mm panel hole. Maximum panel thickness 3mm. 2 x 6.3mm blade terminals. 11A@12V.

16.83 **080807**

Replica version of above.

12.65 **080817**

DOOR SWITCHES

Type



Plastic universal door switch. Single 6.3mm blade terminal (circuit completes through switch body). Centre distance between plunger and fixing screw 10-15mm. Plunger length 0-20mm and is self setting first time door is shut.

Each Part No.
2.20 **081501**



Plastic universal door switch having 2 x 6.3mm blade terminals. Dimensions as above.

2.42 **081502**



Metal universal door switch. Single 6.3mm blade terminal (circuit completes through switch body). Plunger length 11mm, 22mm between fixing holes.

3.63 **081503**



Metal universal door switch as above, except plunger length 4.5mm.

3.69 **081504**

INDICATOR (3-WAY ON/OFF/ON) SWITCHES

Type



Toggle switch. Black plastic knob, with 3 screw terminals. 5A@12V. 13mm fixing hole.

Each Part No.
2.55 **080901**



Toggle switch with turned aluminium lever. Single pole. Requires 13mm panel hole. Maximum panel thickness 2.5mm. Screw terminals. 6A@12V.

3.54 **081702**

INDICATOR (3-WAY ON/OFF/ON) SWITCHES (contd)

Type	Each	Part No.
 Metal toggle switch with plated lever. 6.3mm blade terminals. Requires 13mm panel hole. 16A@12V.	3.63	080103
 Toggle switch with illuminated large green lever. Requires 18.5mm panel hole. Screw terminals. Supplied with 12V bulb.	10.98	080907
 Rotary switch with black plastic lever and screw terminals. Requires 27mm panel hole. 6A@12V. (Matches switch 081004).	10.19	080905
 As above but with illuminated green plastic lever. 6A@12V.	11.29	080902
 Rotary switch with black plastic lever having an integral red warning lamp and screw terminals. Requires 26mm fixing hole. Requires BA7s bulb. Supplied with wiring diagram. Connection details - see page 91.	13.86	080906
 Steering column mounted switch. 110mm stalk with illuminated green knob. Mounts on columns up to 40mm dia. 16A@12V. Supplied with bulb and wiring diagram. Connection details - see page 91.	17.05	080903
 As above but with non-illuminated black knob.	14.37	080904
 Lucas SPB120 indicator switch. Cream plastic with integral red warning lamp. For mounting on dashboard surface. 46mm between mounting hole centres.	35.62	080908
 Lucas SQB114 universal column switch. Mounts on columns up to 38mm dia., but can be adapted to fit bigger diameters. Switch consists of indicator switch (up/down), dip switch (back/front), and horn switch (pushing stalk). Supplied with 450mm of flying leads.	44.55	080910

HAZARD SWITCHES, ETC

Type	Each	Part No.
 Panel mounted push on hazard switch, with illuminated button. Requires 30mm panel hole. Supplied with wiring diagram. Connection details - see page 91.	20.68	081901
 Connector plug for above (081901), including terminals (7 x 050203).	1.39	081902
 Rocker hazard switch - see page 40. Connection details - see page 91.	25.99	081223
 Lucas SFB300 Hazard Kit. Includes hazard flasher relay, switch (with illuminated knob), mounting brackets and instructions to enable hazard lights to be easily fitted to any vehicle with existing indicators.	40.95	081903
 Rocker type hazard switch. Fits 37mm x 18mm aperture. Comes with wiring diagram. 7 x 4.8mm blade connections. Connection details - see page 92.	6.65	081904
 This kit contains an illuminated rocker hazard switch combined with a hazard relay fixed on a common bracket. Negative or positive earth (by reversing relay connections).	9.35	081905
ROTARY SWITCHES		
 On/off, 2 position, water resistant, illuminated rotary switch. Comes complete with 3 different coloured lenses (red, amber, green) and bulb. Black knob. 15A@12V. Fixing hole 13mm. 6.3mm blade terminals.	10.39	081001
 As above, but non-illuminated.	7.52	081005
 Off/OnA/OnA+B/OnA+C, 4 position, water resistant, rotary switch. Black knob. 15A@12V. Fixing hole 13mm. 6.3mm blade terminals.	10.45	081002
 Off/OnA/OnA+B. 3 position water resistant rotary switch. Black knob. 29A@12V. 6.3mm blade terminals. 13mm fixing hole. Suitable for light switch off/side/head.	11.99	081003

ROTARY SWITCHES (contd)

Type

Connector plug for switches 081002 and 081003. Supplied with terminals.

Each Part No.
1.32 **081006**



Off/OnA/OnA+B/OnA+C. 4 position switch with black plastic lever and screw terminals. Requires 27mm panel hole. 11A@12V. (Matches switch 080905).

14.08 **081004**



KEY SWITCHES

Type

On/Off. Double pole switch with metal key and 6.3mm blade terminals. Requires 12mm panel hole. 20A@12V.

Each Part No.
27.50 **081105**



Replacement key for item 081105.

1.95 **081106**



Off/on. 3 terminals, 18.5mm fixing hole, supplied with 2 keys. 6.3mm blade terminals.

16.04 **081101**



Off/ign/start. 5 terminals, 18.5mm fixing hole, supplied with 2 keys. 6.3mm blade terminals.

20.49 **081102**



Off/aux/ign/start. 4 terminals, 18.5mm fixing hole, supplied with 2 keys. 6.3mm blade terminals.

20.25 **081103**



Replacement key for 081101, 081102 & 081103.

3.25 **081107**



Parking/off/ign/side/main/dip. 7 terminals, fixing hole 26.5mm, supplied with 2 keys. 6.3mm blade terminals.

24.75 **081104**



Lucas 128SA 35327 key switch. 4 position switch - off, aux/alt, aux/heater, aux/heater/start. Positions 3 and 4 spring load back to position 2.

25.85 **081110**



DIP SWITCHES

Type

Change over, foot operated dip switch. Screw terminals.

Each Part No.
8.56 **081301**



Lucas 34790 dip switch.

20.79 **081302**



Lucas 31284 foot operated dip switch. Connection via 3 x screw terminals.

25.63 **081303**



ROCKER SWITCHES

Type

On/off. 2 x 6.3mm blade terminals. Case size 33 x 19mm. 10A@12V. 12.5mm fixing hole.

Each Part No.
1.62 **081201**



On/off. 4.8mm blade terminals. Snaps into panel hole 19.5 x 13mm. 10A@12V.

1.62 **081202**



On/off with fluorescent indicator. 6.3mm blade terminals. Snaps into panel hole 30 x 11mm. 16A@12V.

1.67 **081203**



On/off. 4.8mm blade terminals. Snaps into 20mm dia. panel hole. 10A@12V.

1.65 **081204**



As above but illuminated. Available in red or amber.
* Specify colour: Red -R, Amber -A

2.15 **081230-***



On/off with LED indication for on and 4.8mm blade terminals. Snaps into 20mm dia. panel hole. 10A@12V.

2.99 **081205**



On/off. Illuminated. 3 x 6.3mm blade terminals. Case size 33 x 19mm. 10A@12V. 12.5mm fixing hole. Available in blue, green, red or amber.

1.76 **081206-***



* Specify colour: Blue -U, Green -G, Red -R, Amber -A

contd...

ROCKER SWITCHES (contd)

Modular Rocker Switches

Switches that can be mounted individually or clipped together to form a switch panel. Available in all black or with a coloured panel that can be made to illuminate either when switch is 'switched' or, for example, when vehicle lights are turned on. Switch ratings are 15A @ 28V DC. To mount individual switches, the required panel cut out is 44 x 22mm. Supplied with wiring diagrams. (On) = momentarily on.

Black

Type

Off/On
Off/(On)
On/On
On/Off/On
(On)/Off/On
(On)/Off/(On)
Off/On A/On A+B

Each	Part No.
6.73	081207
6.93	081208
7.24	081209
8.73	081210
7.94	081211
8.73	081212
10.82	081213

Coloured Panel

Type

Off/On

* Specify colour: Blue -U, Green -G, Red -R, Amber -A

Each	Part No.
9.17	081214-*

Specific (Back-Lit)

Type

Wiper	Off/On/On	16.95	081215
Washer	Off/(On)	10.52	081216
Rear Screen Wiper	Off/On	9.89	081217
Lights	Off/On A/On A+B	16.43	081218
Side Lights	Off/On	9.89	081219
Front Fog	Off/On	9.89	081220
Rear Fog	Off/On	9.89	081221
Instrument Lights	Off/On	9.89	081222
Hazard Warning*	Off/On	25.99	081223
Fan	Off/On	9.89	081224

Each	Part No.
16.95	081215
10.52	081216
9.89	081217
16.43	081218
9.89	081219
9.89	081220
9.89	081221
9.89	081222
25.99	081223
9.89	081224

* Connection details
- see page 91.



081225



081226



081227

Two types of mounting frames are available:- end frames and middle frames. All clip together. To make the panel shown would take two end frames and one middle frame. The required cut out per frame is 26 x 48mm. To aid connection to each switch a special moulded socket is available (supplied with all terminals).

Type

End Frame
Middle Frame
Terminal Socket & Terminals
Blanking Plate



Each	Part No.
3.17	081225
3.17	081226
3.17	081227
3.17	081228

BRAKE LIGHT SWITCHES

Mechanical

Type

Spring-loaded plunger. Can be pushed or pulled (switch closed at rest). Small hole in plunger shaft for attaching pulling wire if required.

Each	Part No.
3.63	081402



Switch with spring and hook. Makes contact when spring is pulled.

5.72	081401
------	---------------



Switch with spring and clamp. Can be mounted on a flat surface or clamped to a tube (up to 25mm dia). Makes contact when spring is pulled.

6.72	081403
------	---------------



Rubber cover for 081401, 081402 & 081403. Protects terminals from ingress of moisture, etc.

1.65	081404
------	---------------



Plunger switch with M10 x 1.25 fixing thread and two pairs of contacts. When plunger is pressed one pair make and the other pair break. 4 x 6.3mm blade terminals.

9.98	081408
------	---------------



Hydraulic (6.3mm blade connections)

Type

1/8" x 27NPTF (Lucas SMB423).

Each	Part No.
9.20	081405



3/8" x 24UNF (Lucas SPB401).

9.75	081406
------	---------------

M10 x 1 (Lucas SMB426).

8.75	081407
------	---------------

MISCELLANEOUS

Type

Lucas 78405 rheostat. Hexagonal shaft, 0-15 ohms resistance. 2 x 6.3mm blade terminals.

Each	Part No.
37.50	083001



Universal in-line diode. 10A, 150V dc with male (-) and female (+) 6.3mm blade terminals.

1.65	082101
------	---------------



ACCESSORIES

WARNING LAMPS

Type



Warning lamp supplied with 12V, 2W, BA7s bulb. 6.3mm blade terminals. Needs 13mm panel hole. Available in blue, green, red or amber.

* Specify colour: Blue -U, Green -G, Red -R, Amber -A



Warning lamp supplied with 12V, 1.2W, mini capless bulb. 2.8mm blade terminals. Push fit into 10mm panel hole. Available in blue, green, red or amber.

* Specify colour: Blue -U, Green -G, Red -R, Amber -A



Large warning lamp. Needs 9mm BA9s bulb (2W max) and 17mm panel hole. 6.3mm blade terminals. Available in blue, green, red or amber.

* Specify colour: Blue -U, Green -G, Red -R, Amber -A



Older style warning lamp with turned aluminium bezel. Bezel diameter 22mm. Requires 17.5mm panel hole. Maximum panel thickness 10mm. Requires BA9s bulb (not supplied). 2 x screw terminals. Available in blue, green, red or amber.

* Specify colour: Blue -U, Green -G, Red -R, Amber -A



LED warning lamp. Push fit into 8.2mm hole. Supplied with 300mm leads. Polarity sensitive. Available in green, red, amber or red flashing.

* Specify colour: Green -G, Red -R, Amber -A, Red Flashing -RF



Red LED warning lamp with chrome surround. Fits into 8mm panel hole.

CIGAR LIGHTERS & BRACKETS

Type



Cigar lighter, illuminated. Requires 25mm panel hole. Suitable for dashboard mounting. Connection via 2 x 6.3mm blade terminals.

As above, but non-illuminated.

Each Part No.
2.31 090101-*

2.95 090105-*

3.74 090109-*

2.90 090117-*

2.50 090113-*

3.42 090118

Each Part No.
9.13 090205

8.25 090204



Type

Cigar lighter socket only. Non-illuminated. Requires 28mm panel hole.

Each Part No.
4.07 090206



Cigar lighter plug. Fits most cigar lighter sockets with red adapter (supplied) in place. Without red adapter, fits standard DIN socket. Has an internal fuse of 8A.

3.85 090202



Cigar lighter plug with integral replaceable fuse (supplied) and green LED to indicate power is on.

1.96 090207



Bracket for under dashboard mounting of cigar lighters (090204 & 090205). Finished in black.

0.66 090203



Cigar socket doubler. Cigar lighter plug supplying double socket via flexible cable. 10A max.

16.43 090208



Cigar lighter plug extension lead. Coiled cable, 2.45m working length with standard lighter plug and socket. Rated at 5A @ 12V DC continuous.

9.33 090209

DIN SOCKETS & PLUGS

Type



DIN panel socket. Requires 16mm hole. 16A maximum.

Each Part No.
4.38 090301



DIN socket with spring loaded cap. Requires 18mm hole. 2 x 6.3mm blade terminals. 16A maximum.

6.12 090305



DIN surface mount socket. Supplied with fixing screws. 16A maximum.

6.32 090302



Triple DIN Socket. 3 sockets mounted on a panel. Hole required 70 x 20mm. Supplied with fixing screws. 16A maximum.

12.16 090303



DIN plug. To fit all of above DIN sockets. 16A maximum.

3.37 090304

JUNCTION BOXES



Type

4-way circular junction box. 4 screw terminals. 57mm diameter. Lid with retaining screw.

Each Part No.
3.26 **090601**



An 8-way junction box with rubber body and a clear plastic cover. The body has four waterproof cable glands. W110 x D90 x H41mm. Supplied with mounting bolts.

12.10 **090501**



Lucas plastic junction box with removable lid and integral seal. 10 screw terminals. 90mm x 68mm. Four cable entry points.

6.82 **090603**



Junction box with black phenolic body and lid. Waterproof cable glands at each end. Lid secured by knurled nut and sealed by a waterproof gasket. Can accept cables up to 6mm². Screw connections. W125 x D73 x H25mm.

Way

6
12

Each Part No.
11.00 **090401**
14.08 **090402**

FUSING

FUSE BOXES

Continental Type

Available in 2, 4, 6, 8 and 12 way. Moulded phenol base and cover (held on with thumb screw). Available with clear or black cover. Screw terminals. Supplied with 8A continental fuses.

Way

2
4
6
8
12

Each Part No.
4.27 **100101-***
5.71 **100102-***
8.32 **100103-***
11.67 **100104-***
15.56 **100112-***

* Specify colour: Clear -C, Black -B



Connector bridges for the above range of fuse boxes. Useful for joining a number of terminals together.

Type

2-way
3-way
4-way
6-way

Each 10 Part No.
0.77 6.54 **100121**
1.20 10.20 **100122**
1.25 10.87 **100123**
1.32 11.22 **100124**



High quality Bosch manufactured fuse boxes. Moulded black phenol base with black clip-on cover. Supplied with 8A continental fuses.

Way

2
4

Each Part No.
5.24 **100113**
7.46 **100114**



Blade Fuse Type

Surface mounted fuse box for blade type fuses. Available in 4 or 6 way. Black moulded base and transparent cover. Connection via 6.3mm blade terminals on underside. Supplied without fuses.

Way

4
6

Dimensions (mm)

H58 x W52 x D26
H58 x W72 x D26

Each Part No.
2.42 **100105**
2.86 **100106**



Surface mounted fuse box for blade type fuses. Available in 4, 6 or 8 way. Black moulded base, transparent cover and gasket. Connection via 6.3mm blade terminals on each side of fuse box. Supplied without fuses.

Way

4
6
8

Dimensions (mm)

H36 x W79 x D26
H36 x W100 x D26
H36 x W115 x D26

Each Part No.
3.05 **100107**
4.47 **100108**
5.85 **100109**



Type

Surface mounted 16 way blade type fuse box. Black moulded base and transparent cover. Comes with terminals & terminal locking bar. Terminals are crimped onto wires and then inserted into base of fusebox. Supplied without fuses. These fuse boxes can be clipped together to form 32 or 48 way units, and to relay box 140304. (H64 x W123 x D42mm).

Each Part No.
16.89 **100110**



Panel mounted 8 way blade type fuse box. Black with transparent cover and gasket. Designed to fit through a panel aperture. 6.3mm blade connections on underside of box. Supplied without fuses. (H42 x W88 x D32mm).

5.41 **100111**



Lucas Fuse Boxes

SF4. Surface mounted 4-way fuse box. Accepts four glass fuses. Connections via screw terminals. Phenol lid held on with knurled screw. Has space for 2 spare fuses.

42.00 **100116**

Replica version of above Lucas SF4. Almost indistinguishable.

19.20 **100126**

contd...

FUSE BOXES (contd)

Lucas Fuse Boxes (contd)

Type

Each Part No.
20.35 100117

SF6 (37132). Surface mounted 2-way fuse box. Accepts two glass fuses. Connections via screw terminals. No cover. Has space for 2 spare fuses.



4FJ (54038068). Surface mounted 2-way fuse box with detachable cover. Accepts glass fuses. Connections via 6.3mm blade terminals. Has space for two spare fuses.

8.80 100118



6FJ (37409). Panel mounted 4-way fuse box with detachable cover. Accepts glass fuses. Connections via 6.3mm blade terminals on underside. Link between terminals 1 & 3 on underside. Suitable for mounting through a bulkhead. Has space for two spare fuses.

21.88 100119



Picture as above

6FJ (37564). Panel mounted 4-way fuse box with detachable cover. Accepts glass fuses. Connections via 6.3mm blade terminals. Link between terminals 5 & 7 on underside. Suitable for mounting through a bulkhead.

21.88 100125



7FJ (37420). Surface mounted 4-way fuse box with detachable cover. Accepts glass fuses. Connections via side mounted 6.3mm blade terminals. Has space for two spare fuses.

23.15 100120

SINGLE FUSE HOLDERS

Type

Each Part No.
0.65 100201

For continental fuses. Moulded in black phenol. Bayonet fixing with screw terminals. Supplied with 8A fuse.



For continental fuses. Moulded in black phenol. Bayonet fixing with 6.3mm blade terminals. Supplied with 8A fuse.

0.78 100202



For 30mm glass fuses, supplied with flying leads. Moulded in white nylon. Bayonet fixing. No fuse supplied. Current capacity 8A.

0.71 100214



As above, but current capacity 17A.

0.74 100203

For 30mm glass fuses. Moulded in black phenol. Screw cable connections. Supplied with 35A fuse.

2.19 100204



Type

Each Part No.
4.10 100205

Panel mounted fuse holder for 30mm glass fuses up to 35A. Requires 16mm diameter hole. Has 4.8mm blade connections. Screw on cap retains fuse.



Splash proof in-line fuse holder for 30mm fuses up to 20A. Has PVC grommets and O ring. Nickel plated brass screw connections.

3.40 100206



Blade fuse holder. Can be clipped together to form a fuse block. 6.3mm blade connections on each side. Requires mounting plate (100210) to fix it to a surface.

0.74 100207



Blade fuse holder. Can be clipped together to form a fuse block. 6.3mm blade connectors in base. Requires mounting plate (100210) to fix it to a surface.

0.70 100208



Transparent push-on cover for above (100208).

0.19 100209



Mounting plate for above (100208).

0.23 100210



Panel mounted blade fuse holder. Requires mounting hole 22 x 11mm. 6.3mm blade terminals. 30A max.

1.01 100211



Blade fuse holder on flying leads. Current rating 30A.

1.99 100212



'Add a Circuit' blade fuse holder. This item can be used to gain another fused circuit when used to replace an existing fuse within a fuse box.

7.22 100215



'Add a Circuit' mini blade fuse holder. Same as above item but for mini blade fuses.

7.22 100216

Picture as above

Strip fuse holder. Cable connections are made using the protruding M5 studs. Moulded in black plastic. Supplied without fuse.

2.10 100213



FUSES (kits also available - see page 85)

Standard Blade Fuses

Cont. Rating (A)	Fusing (A)	Colour	Each	50	Part No.
1	2	Black	0.15	3.90	100301
2	4	Grey	0.15	3.90	100302
3	6	Violet	0.15	3.90	100303
4	8	Pink	0.15	3.90	100304
5	10	Tan	0.15	3.90	100305
7.5	15	Brown	0.15	3.90	100306
10	20	Red	0.15	3.90	100307
15	30	Blue	0.15	3.90	100308
20	40	Yellow	0.15	3.90	100309
25	50	Natural	0.15	3.90	100310
30	60	Green	0.15	3.90	100311
40	80	Orange	0.15	3.90	100312

Blade Fuse Extractor

Makes extracting blade fuses easier.

Each	Part No.
0.35	100701

Mini Blade Fuses

Cont. Rating (A)	Fusing (A)	Colour	Each	50	Part No.
2	4	Grey	0.18	6.90	101101
3	6	Violet	0.18	6.90	101102
4	8	Pink	0.18	6.90	101103
5	10	Tan	0.18	6.90	101104
7.5	15	Brown	0.18	6.90	101105
10	20	Red	0.18	6.90	101106
15	30	Blue	0.18	6.90	101107
20	40	Yellow	0.18	6.90	101108
25	50	Neutral	0.18	6.90	101109
30	60	Green	0.18	6.90	101110

Continental Fuses

Cont. Rating (A)	Fusing (A)	Colour	Each	50	Part No.
5	10	Yellow	0.15	3.70	100401
8	16	White	0.15	3.70	100402
16	32	Red	0.15	3.70	100403
25	50	Blue	0.15	3.70	100404

Glass Fuses (30mm x 6.3mm)

Cont. Rating (A)	Fusing (A)	Each	50	Part No.
1	2	0.15	3.80	100501
2.5	5	0.15	3.80	100502
5	10	0.15	3.80	100503
7.5	15	0.15	3.80	100504
10	20	0.15	3.80	100505
12.5	25	0.15	3.80	100506
15	30	0.15	3.80	100507
25	50	0.15	3.80	100508

Strip Fuses

Cont. Rating (A)	Fusing (A)	Each	10	Part No.
30	60	0.30	2.38	100601
40	80	0.30	2.38	100602
50	100	0.30	2.38	100603
60	120	0.30	2.38	100604
80	160	0.30	2.38	100605
100	200	0.30	2.38	100606

CIRCUIT BREAKERS

Blade Type

Circuit breakers for 12/24V DC systems. Thermal bi-metallic with manual reset and trip. Replace standard blade fuses in many fuse holders and boxes.

Rating (A)	Each	Part No.
6	14.54	100801
8	14.54	100802
10	14.54	100803
15	14.54	100804
20	14.54	100805
25	14.54	100806

Panel Mounted

Circuit breakers for 12/24V DC systems. Thermal bi-metallic with manual reset. 2 x screw terminals. Panel mounted in 12mm diameter hole.

Rating (A)	Each	Part No.
20	19.52	100901
30	19.52	100902
40	19.52	100903
50	19.52	100904
60	19.52	100905
70	19.52	100906

CABLE SLEEVING

SPIRAL BINDING

An easy and quick way of bundling and protecting cables. It also has the advantage that it can be put on cables whilst in situ. Made from black low density polyethylene (LDPE) with an operating temperature range of -60°C to +50°C.

Dia. (mm)	Wall Thickness (mm)	Bundle Dia. (mm)	m	25m	Part No.
3.0	0.75	1.5-7	0.28	5.50	110103
6.0	1.0	5-20	0.45	9.00	110101
12.0	1.5	10-40	0.75	15.00	110102



CONVOLUTED SLEEVING

Black polyamide convoluted sleeving for bundling and protection of wiring. Operating temp. -40°C to +120°C. Self extinguishing. Petrol, oil and water resistant.

Internal Dia. (mm)	External Dia. (mm)	<u>m</u>	<u>10m</u>	Part No.
6.5	10.0	0.48	4.44	110401
10.0	13.0	0.60	5.45	110406
12.7	16.1	0.73	6.68	110402
16.7	21.2	0.75	6.88	110403
21.4	25.4	0.82	7.42	110407
27.9	34.5	1.21	10.89	110408



PVC SLEEVING

General purpose black PVC sleeving for bundling and protection of cables. Water, oil and petrol resistant. Operating temperature -20°C to +70°C.

Int. Dia. (mm)	Wall Thickness (mm)	<u>m</u>	<u>25m</u>	Part No.
4	0.5	0.23	3.59	110201
5	0.5	0.29	4.47	110202
6	0.5	0.32	5.02	110203
8	0.5	0.37	5.95	110204
10	0.5	0.43	8.32	110205
12	0.5	0.58	12.24	110206
14	0.5	0.69	14.73	110207
16	0.5	0.81	17.17	110208
20	1.0	0.92	19.64	110209
25	1.0	1.09	23.07	110210



HEAT SHRINK SLEEVING

Commercial grade polyolefin heat shrink tubing. Available in black or red. Operating temperature -55°C to +125°C. Shrink ratio of 2:1. Can be shrunk using a standard hot air gun.

Int. Dia. before Heating (mm)	Int. Dia. after Heating (mm)	<u>m</u>	<u>5m</u>	Part No.
3.2	1.6	0.59	2.50	110301-*
4.8	2.4	0.71	3.03	110302-*
6.4	3.2	0.91	3.89	110303-*
9.6	4.8	1.01	4.28	110304-*
12.8	6.4	1.24	5.27	110305-*
19.0	9.5	1.95	8.30	110306-*
25.4**	12.7	2.53	10.75	110307
38.2**	19.1	6.18	26.25	110308

**Only available in black

* Specify colour: Black -B, Red -R



Heatshrink selection pack. One metre each of 110301 to 110306, in black or red.

* Specify colour: Black -B, Red -R

Each	Part No.
5.50	110309-*



EXPANDABLE BRAIDED SLEEVING

Made from black polyester which, because of its woven construction, expands readily to fit a range of cable bundle diameters. Cables can also be routed out through the sleeving wall. It has very good abrasion resistance, and has a temperature range of -70°C to +150°C. To stop fraying, the cut end should be fused using a soldering iron, or covered using heatshrink tubing or neoprene sleeves.

Min Dia. (mm)	Max Dia. (mm)	<u>m</u>	<u>10m</u>	Part No.
3	7	0.62	5.54	110701
5	10	0.86	7.72	110702
10	18	1.50	13.46	110703
15	27	1.61	14.45	110704



TEMPERATURE RESISTANT SLEEVING

Woven material lacquered with polyurethane. Temperature resistant to 155°C. Natural colour.

Int. Dia. (mm)	<u>m</u>	Part No.
1	0.52	110801
2	0.63	110802
4	1.11	110803
6	1.56	110804
8	1.99	110805

(only supplied in 1m lengths)

(only supplied in 1m lengths)



NEOPRENE SLEEVES

Used for insulating and finishing non-insulated terminals. Sleeves are pre-lubricated and applied using special application tool (150102, page 87). Sleeve colour is black. Operating temperature range -65°C to +130°C.

Length (mm)	Wall Thickness (mm)	Bore Dia. (mm)	Max Cable Dia. (mm)	<u>100</u>	Part No.
20	0.75	1.5	3.0	2.66	110506
20	0.75	2.0	4.0	3.10	110507
20	0.75	3.0	6.0	2.38	110508
25	1.0	5.0	10.0	8.05	110509
25	1.25	7.5	15.0	5.61	110510

CABLE MARKERS

Clip On

Available in 3 sizes in handy packs. Useful for marking cable after termination as markers are simply clipped on the side of the cable. Packs contain equal numbers of 0, 1, 2, 3, 4, 5, 6, 7, 8 & 9. Each number is a different colour.

Cable OD (mm)	Pack size	Each	Part No.
2.0-2.8	200	8.12	110902
2.8-3.8	200	8.25	110903
4.3-5.3	100	4.16	110904



contd...



CABLE MARKERS (contd)

Heat Shrink

Manufactured from white heat-shrink with black text. Shrink ratio of 3:1 when heated above 120°C. Sold in assorted bags of 100, each bag having 10 of 0, 1, 2, 3, 4, 5, 6, 7, 8, & 9.

Initial Size (mm)	Min. Size after Heating (mm)	Each	Part No.
6	2	5.93	110901
12	4	7.78	060901



Slide On

Made from coloured PVC. Designed for easy fitting without tools. Fit cables from 2-5mm in diameter. 500 markers per pack, approximately 50 each of 0, 1, 2, 3, 4, 5, 6, 7, 8 & 9.

Each	Part No.
8.10	110905

CABLE FIXING

P CLIPS

Black Nylon (kit also available - see page 86)

Fixing hole 4.6mm

Internal Dia. (mm)	10	50	Part No.
3.2	0.43	1.83	120101
4.8	0.44	1.87	120102
6.4	0.47	2.01	120103
7.9	0.52	2.20	120104
9.5	0.55	2.34	120105
12.7	0.68	2.90	120106
15.8	0.79	3.37	120107
19.4	1.04	4.44	120108
25.4	1.20	5.09	120109
31.8	1.42	6.03	120110

Steel (kit also available - see page 86)

Black rubber covered steel P-clips. Rubber covering helps protect against chafing, etc. Fixing hole 6.8mm.

Internal Dia. (mm)	Each	10	Part No.
3.2	0.21	1.78	120301
4.8	0.23	1.97	120302
6.4	0.24	2.06	120303
7.9	0.25	2.16	120304
9.5	0.26	2.24	120305
12.7	0.33	2.81	120306
15.9	0.36	3.09	120307
19.0	0.44	3.74	120308
22.2	0.47	4.03	120309
25.4	0.51	4.30	120310



Brass (kit also available - see page 85)

Internal Dia. (mm)	Fixing Hole (mm)	Each	10	Part No.
5.0	3.2	0.31	2.62	120401
10.0	4.2	0.47	4.03	120402
15.0	5.0	0.46	3.93	120403
20.0	6.4	0.48	4.11	120404
22.0	5.0	0.65	5.52	120405
25.0	5.0	0.97	8.23	120406



Aluminium

Black rubber covered aluminium P-clips. Fixing hole 5.2mm.

Internal Dia. (mm)	Each	10	Part No.
4.8	0.71	6.03	120201
6.4	0.75	6.38	120202
7.9	0.76	6.46	120203
9.5	0.80	6.80	120204
12.7	0.92	7.82	120205
15.9	0.98	8.33	120206
19.1	1.10	9.35	120207
22.2	1.20	10.20	120208
25.4	1.26	10.71	120209

120501



120502



120503



120504



120505



CHASSIS CLIPS

Clip-On (Large)

Plated steel, 12.7mm wide. Simply clip on to chassis.

Length (mm)	Max Cable Dia. (mm)	Each	10	Part No.
42	6.5	0.67	5.71	120501
52	5.5	0.45	3.84	120502
57	5.5	0.49	4.21	120503
44	6.5	0.45	3.84	120504
39	10.0	0.36	3.09	120505

Clip-On (Small)

Plated steel. Simply clip on to chassis. Available for two chassis thicknesses.

Chassis thickness (mm)	Cable dia. (mm)	Each	10	Part No.
2-4	6-7	0.44	3.74	120506
2-4	8-9	0.45	3.84	120507
2-4	10-11	0.45	3.84	120508
2-4	12-14	0.47	4.03	120509
4-7	6-7	0.44	3.74	120510
4-7	8-9	0.45	3.84	120511
4-7	10-11	0.45	3.84	120512
4-7	12-14	0.47	4.03	120513

Bolt On

Plated steel with a hole to bolt on to chassis.

Max Cable O/D (mm)	Hole Dia. (mm)	10	25	Part No.
3	5	1.76	3.74	120601
5	6.3	1.76	3.74	120602
8	5	1.76	3.74	120603
10	5	1.76	3.74	120604
12	5	1.76	3.74	120605
15	5	1.87	3.97	120606

CHASSIS CLIPS (contd)

Saddle Clips

Plated steel with 2 x 4mm mounting holes.

Max Cable Size	Mounting Hole Centre Dist. (mm)	Each	10	Part No.
6mm OD	20	0.17	1.32	121901
12.7 x 6.35mm	26	0.20	1.65	121902

Self Adhesive

Nylon cable mounting clips with a self adhesive base. Suitable for fixing round or flat cables. Natural colour nylon.

Max Cable Dia. (mm)	Base Size (mm)	Each	10	Part No.
3.8	16 x 16	0.17	1.41	120701
7.7	25 x 25	0.21	1.78	120702
12.0	28 x 28	0.24	2.06	120703

Aluminium self adhesive cable mounting clips. Two sizes available.

Max Cable Dia. (mm)	Base Size (mm)	10	25	Part No.
6.0	11 x 16	0.94	1.99	120704
9.5	16 x 19	1.33	2.83	120705

CABLE TIES

Black Nylon

Length (mm)	Width (mm)	10	100	Part No.
102	2.5	0.23	0.66	120801
150	3.6	0.27	1.38	120804
165	2.5	0.28	1.39	120802
190	4.8	0.44	2.20	120806
200	2.5	0.32	1.62	120803
240	7.6	0.92	5.31	120809
292	3.6	0.65	3.46	120805
368	4.8	0.69	4.62	120807
380	7.6	1.83	9.13	120810
450	4.8	1.39	9.24	120808

White Nylon with Marker Plate

Length (mm)	Width (mm)	10	100	Part No.
100	2.5	0.85	4.24	120901

BUCKLE CLIPS

Useful for securing looms and cables where a period look is preferred.

Size (mm)	Material	Each	10	Part No.
102 x 6	Aluminium	0.35	3.25	121801
178 x 8	Aluminium	0.46	3.93	121802
178 x 8	Brass	0.76	6.46	121804

CABLE TIE MOUNTS

Self-Adhesive

Type

Four-way self adhesive mount. Max. width of cable ties 3.2mm. Mount size 21 x 21mm. Made from black plastic. Also has fixing hole.

Each	25	Part No.
0.15	1.76	121001

Two-way self adhesive mount. Max. width of cable ties 4.8mm. Mount size 25 x 25mm. Made from black plastic. Also has fixing hole.

0.18	3.60	121002
------	------	--------

Cable Tie Eyelets

Made from black nylon.

Max. cable tie width (mm)

Type	10	25	Part No.	
4.8	1	0.77	1.65	121003
9.0	1	0.99	2.09	121004
4.8	2	0.77	1.65	121005

GROMMETS

Wiring Grommets (kit also available - see page 85)

Black PVC, slot width 1.6mm.

Panel Hole Size (mm)	Grommet OD (mm)	Grommet ID (mm)	Each	10	25	Part No.
6.4	9.5	4.0	-	0.40	0.70	121101
7.9	11.0	5.5	-	0.45	0.80	121102
9.3	13.4	7.7	-	0.50	0.90	121103
12.3	16.2	9.5	-	0.65	1.15	121104
15.8	19.0	12.0	-	0.90	1.65	121105
20.2	23.0	15.8	-	1.55	2.85	121106
25.0	29.2	19.5	-	1.70	3.40	121107
31.0	38.1	24.0	0.25	1.76	-	121108
37.4	46.0	31.5	0.49	3.11	-	121109
50.5	60.3	44.5	0.57	4.37	-	121110

Blanking Grommets (kit also available - see page 85)

Black PVC, slot width 1.6mm.

Panel Hole Size (mm)	Grommet OD (mm)	Each	10	25	Part No.
6.4	8.5	-	0.61	1.20	121201
9.3	13.4	-	0.72	1.35	121202
12.3	16.2	-	0.85	1.49	121203
15.8	19.0	-	1.00	1.78	121204
20.0	24.2	-	1.40	2.43	121205
25.0	29.2	-	1.64	2.86	121206
31.7	38.1	0.31	1.98	-	121207
37.7	44.4	0.51	3.50	-	121208
50.5	57.2	0.81	5.68	-	121209

GROMMET STRIP

Natural Coloured

Ideal for irregular shaped openings. Made from natural coloured polythene. Available for three different panel thicknesses.

Panel thickness (mm)	m	5m	Part No.
1.0-1.3	0.70	3.30	121111
1.3-2.1	0.79	3.70	121112
2.1-3.3	0.81	3.81	121113

Black

Grommet strip made from black PVC, which has excellent flexibility, a temperature range from -65 to 105 deg C and is self extinguishing. Suitable for panel thicknesses from 1-1.6mm.

m	5m	Part No.
0.79	3.70	121114

TAPE

PVC Tape

Self adhesive PVC tape. Temp. range 0°C to +70°C. Thickness 0.13mm.

Width (mm)	Length (m)	Colour	Each	10	Part No.
19	20	Black	0.85	7.52	121301
19	20	Red	0.85	7.52	121302
19	20	Green	0.85	7.52	121303
19	20	Blue	0.85	7.52	121304
19	20	Yellow	0.85	7.52	121305
19	20	Brown	0.85	7.52	121306
19	20	White	0.85	7.52	121307

PVC Harness Tape

Non adhesive PVC tape used for wrapping wiring looms to protect against abrasion, etc. Flame retardent. Operating temp. 0°C to +90°C. Thickness 0.13mm.

Width (mm)	Length (m)	Colour	Each	10	Part No.
19	20	Black	1.39	11.78	121401
25	20	Black	1.76	14.96	121402
22	20	Blue	1.54	13.09	121403
22	20	Yellow	1.54	13.09	121404

Self Amalgamating Tape

Strong self amalgamating polyisobutylene elastic tape which, when wrapped onto itself, will amalgamate creating a water-tight seal. Operating temp. -95°C to +90°C. Thickness 0.5mm. 25mm wide, 10m long.

Each	Part No.
7.15	121501

Cloth Insulating Tape

An old-style electrical tape useful for insulation and harness wrapping. Black cotton with a natural rubber adhesive. 19mm x 20m long. 0.35mm thick.

4.24	121601
------	---------------

BULBS & BULB HOLDERS



PANEL BULB

Replacement bulb for part numbers 081214 - 081224 inclusive. "Cap" dimensions 2mm x 4.6mm.

Volts	Watts	Each	10	Part No.
12	1.2	0.43	3.64	132201



MES MINIATURE SCREW IN

Volts	Watts	Filament	Each	10	Part No.
6	2	Single	0.45	3.87	130104
12	3	Single	0.45	3.87	130102
12	6	Single	0.45	3.87	130105



BA7s MINIATURE BAYONET

Cap 7mm OD, single contact.

Volts	Watts	Filament	Each	10	Part No.
6	1.2	Single	0.52	4.41	130201
12	2	Single	0.50	4.19	130202



BA9s MINUTE BAYONET

Cap 9mm OD, single contact.

Volts	Watts	Filament	Each	10	Part No.
6	3	Single	0.44	3.76	130301
12	2.2	Single	0.42	3.55	130302
12	4	Single	0.44	3.76	130303



BA15s BAYONET

Cap 15mm OD, single contact.

Small Globe

Volts	Watts	Filament	Each	10	Part No.
6	5	Single	0.45	3.87	130401
6	10	Single	0.45	3.87	130402
12	5	Single	0.43	3.65	130403
12	10	Single	0.43	3.65	130404
12	23	Single	0.57	4.84	130405

Medium Globe

Volts	Watts	Filament	Each	10	Part No.
6	21	Single	0.48	4.08	130501
12	21	Single	0.45	3.87	130502
12	21	Single (Amber)	0.76	6.46	130503

contd...



BA15s BAYONET (contd)

Large Globe

Volts	Watts	Filament	Each	10	Part No.
12	36	Single	1.68	14.30	130601
12	45	Single	2.41	20.43	130602
12	50	Single (Halogen)	3.67	31.19	130603

Standard

Halogen

BA15d BAYONET

Cap 15mm OD, double contact, parallel pins.

Small Globe

Volts	Watts	Filament	Each	10	Part No.
6	5	Single	0.48	4.08	130701
6	10	Single	0.57	4.84	130702
12	5	Single	0.48	4.08	130703
12	10	Single	0.59	5.05	130704

Medium Globe

Volts	Watts	Filament	Each	10	Part No.
6	18	Single	0.64	5.38	130801
12	21	Single	0.44	3.76	130802
12	21/5	Double	0.59	5.05	130803

Large Globe

Volts	Watts	Filament	Each	10	Part No.
6	35/35	Double	2.46	20.97	130904
6	25/25	Double (Halogen)	9.08	-	130908
12	36/36	Double	1.86	15.81	130901
12	36	Single	1.90	16.13	130902
12	45	Single	2.31	19.68	130903
12	45/40	Double (Halogen)	9.08	-	130906

Standard

Halogen

BAY15d BAYONET

Cap 15mm OD, double contact, offset pins.

Small Globe

Useful when trying to fit double filament bulbs into confined spaces, eg. existing sidelights.

Volts	Watts	Filament	Each	10	Part No.
6	21/5	Double	1.52	12.90	131004
12	23/8	Double	1.52	12.90	131003

Medium Globe

Volts	Watts	Filament	Each	10	Part No.
6	21/5	Double	0.59	5.05	131001
12	21/5	Double	0.45	3.87	131002



LED BULBS

These 12V bulbs fit into standard bayonet fitting bulb holders and are a replacement for normal bulbs. They have the advantage of being extremely long-lasting and require very little current, typically 30mA. Negative earth only. For best results use the same colour LEDs behind the same colour lenses.

9 LEDs (all LEDs facing rearwards)

Similar in intensity to 5W bulb. Cap OD 15mm, single contact, parallel pins. 18mm diameter, 32mm long.

Colour	Fitting	Each	Part No.
Amber	BA15s	4.25	132405
Red	BA15s	4.25	132406
Clear	BA15s	7.25	132407



19 LEDs (all LEDs facing rearwards)

Similar in intensity to 21W bulb. Cap OD 15mm. 25mm diameter, 46mm long.

Colour	Fitting	Each	Part No.
Amber	BA15s	5.25	132401
Red	BA15s	5.25	132402
Red	BAY15d (stop/tail)	5.25	132404



24 LEDs (18 LEDs facing rearwards, 6 radially sideways)

These are similar in intensity to 21W bulbs but also have the advantage of illuminating the inside of the lamp unit or reflector. Cap OD 15mm. 25mm diameter, 38mm long.

Colour	Fitting	Each	Part No.
Amber	BA15s	7.25	132408
Red	BA15s	7.25	132409
Red	BAY15d (stop/tail)	7.25	132410
Red/White*	BAY15d (stop/tail)	11.50	132411



* Has 18 red rearward facing LEDs and 6 white radial sideways LEDs - useful for lamps with apertures or for number plates.

BOSCH

BA20s

Cap OD 20mm, single contact, unequal-sized parallel flat tabs.

Volts	Watts	Filament	Each	10	Part No.
6	35	Single	1.90	16.13	131101
12	45	Single	1.68	14.30	131102



BA20d

Cap OD 20mm, double contact, unequal-sized parallel flat tabs.

Volts	Watts	Filament	Each	10	Part No.
6	45/40	Double	1.90	16.13	131201
6	35/35	Double (Halogen)	3.04	25.81	131204
12	45/40	Double	1.68	14.30	131202
12	45	Single	1.90	16.13	131203
12	35/35	Double (Halogen)	3.04	25.81	131205



Standard

Halogen (style may vary)



MARCHAL

Cap OD 21mm, with three parallel pins equally spaced around the circumference.

Volts	Watts	Filament	Each	10	Part No.
6	40/45	Double	4.05	34.41	132103
12	40/45	Double	4.43	37.63	132102
12	40/45	Double (Yellow)	4.43	37.63	132104
12	45	Single	4.30	36.56	132101

BRITISH PRE-FOCUS

P36s

Cap OD 36mm, single contact.

Volts	Watts	Filament	Each	10	Part No.
12	48	Single	2.00	16.98	131301



P36d

Cap OD 36mm, double contact.

Volts	Watts	Filament	Each	10	Part No.
6	30/24	Double	2.53	21.51	131401
6	35/35	Double (Halogen)	9.08	-	131404
12	50/40	Double	2.10	17.85	131402
12	38	Single	2.00	16.98	131403
12	60/55	Double (Halogen)	9.08	-	131405



Standard



Halogen

P43t H4

Volts	Watts	Filament	Each	Part No.
6	60/55	Double (Halogen)	5.72	131501
12	60/55	Double (Halogen)	2.28	131502
12	100/80	Double (Halogen)	5.45	131503



P45t

Volts	Watts	Filament	Each	Part No.
6	45/40	Double	2.28	131601
6	60/55	Double (Halogen)	7.43	131602
12	45/40	Double	1.46	131603
12	60/55	Double (Halogen)	2.95	131604
12	100/80	Double (Halogen)	6.60	131605



Standard



Halogen



FESTOON BULBS

Size (mm)	Volts	Watts	Each	10	Part No.
8 x 31	6	3	0.55	4.68	131703
8 x 31	6	5	0.55	4.68	131704
11 x 35	6	6	0.55	4.68	131706
11 x 38	6	5	0.55	4.68	131701
11 x 38	6	10	0.55	4.68	131707
11 x 42	6	10	0.55	4.68	131801
11 x 42	6	15	0.55	4.68	131804
15 x 42	6	15	0.55	4.68	131901
15 x 42	6	21	0.55	4.68	131902
6 x 36	12	3	0.55	4.68	131709
8 x 36	12	3	0.55	4.68	131708
11 x 30	12	10	0.55	4.68	131711
11 x 35	12	5	0.55	4.68	131710
11 x 35	12	10	0.55	4.68	131712
11 x 38	12	5	0.55	4.68	131702
11 x 42	12	5	0.55	4.68	131802
11 x 42	12	10	0.55	4.68	131803
15 x 42	12	10	0.55	4.68	131905
15 x 42	12	15	0.55	4.68	131903
15 x 42	12	21	0.55	4.68	131904

CAPLESS BULBS

Type	Application	Volts	Watts	Each	Part No.
W2 x 4.6d (T5)	Panel light	12	1.2	0.43	132201
W2.1 x 9.5d (T10)	Sidelight	12	5	0.43	132202
W3 x 16d (T20)	Indicator	12	21	0.94	132203



BULB HOLDERS

BAY15d

Offset pins, double contacts, 2 screw connections. For use with bulbs having cap OD of 15mm.

Each	Part No.
2.28	132001



BA15d

Parallel pins, double contacts, 2 screw connections. For use with bulbs having cap OD of 15mm.

Each	Part No.
2.28	132002



BULB HOLDERS (contd)

BA15s

Type

Parallel pins, single contact, single screw connection. For use with bulbs having cap OD of 15mm.

Each Part No.
1.14 **132003**

Parallel pins, single contact, 2 screw connections (1 ground). For use with bulbs having cap OD of 15mm.

2.42 **132004**

BA9s

Type

Single contact, single screw connection. Earths through metal case. For use with bulbs having cap OD of 9mm.

Each Part No.
0.95 **132005**

Insulated bulb holder. 2 x 6.3mm blade connections. 11.9mm OD. For use with bulbs having cap OD of 9mm.

1.05 **132019**

BA7s

Single contact, single screw connection. Earths through metal case. For use with bulbs having cap OD of 7mm.

0.95 **132006**

MES

Type

Non-insulated bulb holder, with claws to fit 5/8" dia. panel hole. Supplied with rivet to be crimped or soldered to wire. Bulb is earthed through casing.

Each Part No.
1.85 **132008**

Insulated bulb holder, with insulated claws to fit 5/8" dia. panel hole. Supplied with rivet to be crimped or soldered to wire. Suitable for charge warning lamps, etc.

1.54 **132009**

Spare rivets for above.

0.02 **132017**

Capless

Insulated T10 (W2.1 x 9.5d) bulb holder. 2 x 6.3mm blade connections. 12.0mm OD.

0.66 **132018**

Festoon

Bulb holder suitable for taking 35mm long festoon bulbs. Single screw mounting hole.

4.68 **132021**

REPAIR BULB HOLDERS

Useful for repairing reflectors with damaged/missing bulb holders. Will fit into 22mm diameter hole. Bulb holder edge is then peened over to attach.

Type

Single contact, parallel pins (BA15s)
Double contact, offset pins (BAY15d)

Each Part No.
4.95 **132014**
4.95 **132015**

REPLACEMENT LUCAS BULB HOLDERS

These bulb holders are for use with the following range of Lucas lights.

Lucas L594

Type

Single contact, parallel pins (BA15s)
Double contact, offset pins (BAY15d)

Each Part No.
4.62 **132010**
4.62 **132011**

Lucas L488

Type

Single contact, parallel pins (BA15s)
Double contact, offset pins (BAY15d)

Each Part No.
4.95 **132012**
4.95 **132013**

Lucas L1130

Double contact, offset pins (BAY15d)

10.25 **132020**

LIGHTING

HEADLAMPS & ACCESSORIES

Mounting Bowls and Ring

Headlamp bowl to take 7" sealed beam or 7" metal reflectors. Made from tough black plastic. Comes complete with chrome-plated lens retaining bezel, bodywork sealing gasket, cable grommet and retaining screws.

Each Part No.
13.44 **170101**

As above but for 5.75" light units.

15.99 **170106**

Headlamp mounting ring. As above but without the bowl. Useful for mounting headlamps in confined spaces. Takes 7" sealed beam or 7" metal reflectors.

15.02 **170102**

contd...

HEADLAMPS & ACCESSORIES (contd)

Sealed Beam Units

7" sealed beam unit. 12V, 60/45W. Has side-light glass window.

Each Part No.
7.92 **170103**

5.75" sealed beam unit. Single filament. 12V, 50W.

8.71 **170107**

European (ie. right-hand dip) versions of the above lamps are also available - please phone for details.

Halogen Conversions

Consist of metal reflectors that take P43t H4 tungsten halogen bulbs. These units are physically interchangeable with sealed or semi-sealed beam lamps and the bulbs have the same electrical connection. Available with or without side light aperture. Bulbs need to be ordered separately (see page xx).

Type

7" without sidelight

Each Part No.
16.50 **170112**

7" with sidelight

16.50 **170113**

5.75" without sidelight

13.50 **170109**

5.75" with sidelight

13.50 **170110**

European (ie. right-hand dip) versions of the above lamps are also available - please phone for details.

Headlamp Harnesses

Headlamp harness suitable for all headlight types without integral sidelights. Comes with headlamp connecting plug, 80cm of cables, sleeving, headlamp shell grommet and bullet connectors. Suitable for use with 170107, 170112 & 170109.

Each Part No.
7.00 **170201**

Headlamp harness suitable for sealed beam units with sidelight windows. Comes with headlamp connecting plug with sidelight bulb holder, 1m of cables, sleeving, headlamp shell grommet and bullet connectors. Requires T10 bulb (132202). Suitable for use with 170103.

7.90 **170202**

Headlamp harness suitable for metal reflectors, with hole for clip-in sidelight bulb holder. Comes complete with headlamp connecting plug, rubber dust cover, separate sidelight bulb holder, 1m of cables, sleeving, headlamp shell grommet and bullet connectors. Requires T10 bulb (132202). Suitable for use with 170113 & 170110.

9.03 **170203**

Headlamp Rims

Chrome-plated rims to fit 7" headlamp bowls (170101) and headlamp mounting rings (170102). Held in place with a retaining screw. Available in two diameters.

Outside diameter

8.5"

Each Part No.
16.09 **170301**

8"

14.92 **170302**

Black plastic rim to fit 5.75" headlamp bowl.

6.64 **170303**

Classic-Style Headlamps

Classic free-standing headlamps with 60/55W halogen bulbs. Come complete with integral sidelight and lead. Available in either polished stainless steel or black finish and with either 7" or 5.75" diameter reflectors.

Type

7" polished stainless steel

Each Part No.
79.00 **170401**

7" black

79.00 **170402**

5.75" polished stainless steel

73.00 **170403**

5.75" black

73.00 **170404**

Off-Road Driving Lamps

Wipac 4x4 driving lamp. High power 12V, 100W, 8" diameter halogen lamps. Available with either black or stainless steel body, both with stainless steel rim. Supplied with armoured cable and fitted plastic stone guard. Sold as pair only.

Type

Black body

Pair Part No.
54.99 **170411**

Stainless steel body

76.99 **170412**

Headlamp Shells

Lucas S700 free-standing 7" headlamp shell with rim. Comes complete with 600mm lead with bullet terminals on one end and headlamp plug inside lamp. Black with chrome rim. Will take sealed beam units or halogen conversions. Requires at least three W-clips to hold in light unit.

Type

Headlamp shell

Each Part No.
59.00 **170405**

W Clip

0.66 **170410**

REAR LAMPS

Type

Each Part No.
4.26 170506



Tail lamp. Rubber-mounted black plastic base with red lens. Two holes for fixing screws. 62 x 62 x 46mm. E-marked. Requires 5W festoon bulb (131702 - see page 61).

5.45 170507



Tail lamp. Steel base plate with lens secured by chrome ring. Two holes for fixing screws. 70mm diameter x 36mm deep. E-marked. Requires 5W festoon bulb (131702 - see page 61).

6.57 170508



Tail lamp. Steel base plate with red plastic lens and illuminating window for number plate. Supplied with fixing bolts and grommet. 75mm diameter x 40mm deep. E-marked. Requires 5W festoon bulb (131802 - see page 61).

14.50 170509



Lucas L594 stop/tail lamp. 72mm diameter rubber base with 54mm diameter domed glass lens. Supplied with 12V, 21/5W bulb. Overall length approx. 100mm including lens. Spare parts are available separately (see page 74).

7.91 170603



Pattern version of Lucas L594 with plastic lens. Supplied with bulb and 20cm of cable with bullet terminals.

15.50 170510



Lucas L488 stop/tail lamp. 72mm diameter rubber base with 54mm diameter flat glass lens. Supplied with 12V, 21/5W bulb. Overall length approx. 100mm including lens. Spare parts are available separately (see page 74).

16.75 170511



Lucas L691 stop/tail lamp. 83mm diameter chromed metal base with 80mm diameter domed plastic lens. Supplied with 12V, 21/5W bulb, 600mm leads with bullet terminals and sealing gasket. Overall length approx. 90mm including lens. E-marked.

Type

Each Part No.
24.95 170512



Lucas L539 stop/tail lamp. 83mm diameter chromed metal base with 65mm diameter domed plastic lens. Supplied with 12V, 21/5W bulb, 600mm leads with bullet terminals and sealing gasket. Overall length approx. 75mm including lens.

10.54 170514



Rubber bodied tail lamp. 56mm diameter with a slightly curved plastic lens. Requires 30mm diameter panel hole. Overall length 78mm. Requires 12V, 5W BA15s bulb (130403 - see page 57).

11.97 170515



Rubber bodied marker lamp that can be used as a discrete tail lamp. Body diameter 56mm, lens diameter 35mm. Overall length 91mm. Supplied with mounting bracket. E-marked. Requires 12V, 5W BA15s bulb (130403 - see page 57).

14.66 170516



Surface mounted modern style stop/tail lamp. 94 mm diameter. Connection via 3 pin econoseal socket (051204 - see page 16) which needs to be purchased separately. Supplied with 12V, 21/5W bulb and sealing gasket. Can be bezel mounted. E-marked.

15.77 170517

As above but tail lamp only. Connection via 2 pin econoseal socket (051202 - see page 16) which needs to be purchased separately. Supplied with 12V, 5W bulb and sealing gasket. Can be bezel mounted.

1.85 170416



Mounting bezel for above lamps (170516 & 170517).

23.00 170518



Lucas L549 stop/tail lamp. Supplied with 12V, 21/5W bulb and sealing gasket.

15.52 170519



Stop/tail lamp with number plate illumination lens and reflector. 78mm diameter. Requires 35mm panel hole. Supplied with 12V, 21/5W bulb. E-marked.

contd...

REAR LAMPS (contd)

Reproduction Lucas ST51 split window 'D' light. Has two BA15s bulb holders and is supplied with 12V bulbs; one 5W for tail light, one 21W for brake light. Has side window for number plate lamp illumination.

Type	Each	Part No.
Chrome	40.00	170501-S
Black	40.00	170502-S

Reproduction Lucas ST38 'Pork Pie' light. Three bulb holders, two for tail lights and one for stop. Has side light window for number plate illumination. 90mm dia. x 60mm deep. Comes with 12V bulbs. Available in black or chrome.

Type	Each	Part No.
Chrome	40.00	170503-C
Black	40.00	170503

The above lamp is also available with a different lens, one half being amber, so the unit can be a combined stop/tail and indicator light. It has three bulbs, one 5W side light, one 21W indicator and one 21W brake light. The light is internally wired and is supplied with leads ready for connection.

Type	Each	Part No.
Chrome	55.00	170503-CI
Black	55.00	170503-BI

Combined tail light and indicator light. 77mm diameter by 60mm deep. Black metal case. Comes complete with cable grommet and mounting bolts. Requires 43mm festoon bulbs (131802 & 131904 - see page 61).

Each	Part No.
29.64	170505

SIDE LAMPS

Lucas L594 side lamp. 72mm diameter rubber base with 54mm diameter domed glass lens. Supplied with 12V, 5W bulb. Overall length approx. 100mm including lens. Spare parts are available separately (see page 74).

Each	Part No.
14.50	170609

Double-pole version of above lamp. Will take 21/5W bulb, which turns lamp into indicator/side light.

14.50	170622
-------	---------------

Pattern version of Lucas L594 with plastic lens. Supplied with bulb and 20cm of cable with bullet terminals.

7.91	170601
------	---------------

Flush-fit version of above (170601) with single filament 5W festoon bulb.

4.46	170604
------	---------------

Type

Lucas L488 side lamp. 72mm diameter rubber base with 54mm diameter flat glass lens. Supplied with 12V, 5W bulb. Overall length approx. 100mm including lens. Spare parts are available separately (see page 74).

Each	Part No.
15.50	170610

Double-pole version of above lamp. Will take 21/5W bulb, which turns lamp into indicator/side light.

15.50	170621
-------	---------------

Lucas L691 side lamp. 83mm diameter chromed metal base with 80mm diameter domed plastic lens. Supplied with 12V, 5W bulb, 600mm leads with bullet terminals and sealing gasket. Overall length approx. 90mm including lens. E-marked.

16.75	170611
-------	---------------

Lucas L539 side lamp. 83mm diameter chromed metal base with 65mm diameter domed plastic lens. Supplied with 12V, 5W bulb, 600mm leads with bullet terminals and sealing gasket. Overall length approx. 75mm including lens.

24.95	170612
-------	---------------

Rubber bodied side lamp. 56mm diameter with a slightly curved plastic lens. Requires 30mm diameter panel hole. Overall length 78mm. E-marked. Requires 12V, 5W BA15s bulb (130403 - see page 57).

10.54	170613
-------	---------------

Rubber bodied marker lamp that can be used as a discrete side lamp. Body diameter 46mm, lens diameter 35mm. Overall length 91mm. Supplied with mounting bracket. E-marked. Requires 12V, 5W BA15s bulb (130403).

11.97	170615
-------	---------------

Surface mounted modern style side lamp. Connection via 2 pin econoseal socket (051202 - see page 16) which needs to be purchased separately. Supplied with 12V, 5W bulb and sealing gasket. Can be bezel mounted. E-marked.

14.66	170616
-------	---------------

Mounting bezel for above lamp (170616).

1.85	170416
------	---------------

Lucas 1130 side/indicator lamp with double pole bulb holder, metal rim and glass effect lens. Supplied with 12V, 21/5W bulb. Spare bulb holders are available separately (see page 63).

42.50	170619
-------	---------------

INDICATOR LAMPS

Type

Each Part No.
14.50 **171009**



Lucas L594 indicator lamp. 72mm diameter rubber base with 54mm diameter domed amber glass lens. Supplied with 12V, 21W bulb. Overall length approx. 100mm including lens. E-marked. Spare parts are available separately (see page 74).



Pattern version of Lucas L594 with amber plastic lens. Supplied with bulb and 20cm of cable with bullet terminals.

7.91 **170602**



Flush-fit version of above (170602). Requires 21W festoon bulb, part no. 131904 (12V) or 131902 (6V) - see page 61.

4.46 **170605**



Lucas L488 indicator lamp. 72mm diameter rubber base with 54mm diameter flat amber glass lens. Supplied with 12V, 21W bulb. Overall length approx. 100mm including lens. Spare parts are available separately (see page 74).

15.50 **171010**



Lucas L691 indicator lamp. 83mm diameter chromed metal base with 80mm diameter domed amber plastic lens. Supplied with 12V, 21W bulb, 600mm leads with bullet terminals and sealing gasket. Overall length approx. 90mm including lens. E-marked.

16.75 **171011**



Lucas L539 indicator lamp. 83mm diameter chromed metal base with 65mm diameter domed amber plastic lens. Supplied with 12V, 21W bulb, 600mm leads with bullet terminals and sealing gasket. Overall length approx. 75mm including lens.

24.95 **171012**



Rubber bodied marker lamp that can be used as a discrete indicator lamp. Body diameter 46mm, lens diameter 35mm. Overall length 91mm. Supplied with mounting bracket. Requires BA15s bulb. Recommended for use with 19 LED bulb, part no. 132401.

11.97 **170607**

*Please note: This lamp unit was designed for use with standard 5W bulbs. If used with standard 21W bulbs in a **non-flashing** mode, damage to the light unit will occur due to the heat generated.*

Type

Each Part No.
14.66 **171016**



Surface mounted modern style indicator lamp. 94mm diameter. Connection via 2 pin econoseal socket (051202 - see page 16) which needs to be purchased separately. Supplied with 12V, 21W bulb and sealing gasket. Can be bezel mounted. E-marked.

As above but rear indicator lamp. Connection via 2 pin econoseal socket (051202 - see page 16) which needs to be purchased separately. Supplied with 12V, 21W bulb and sealing gasket. Can be bezel mounted. E-marked.

14.66 **171017**



Mounting bezel for above lamps (171016 & 171017).

1.85 **170416**

INDICATOR REPEATER LAMPS

Type

Each Part No.
3.95 **171020**



41mm diameter round repeater lamp. 2 x fixing studs. 6.3mm blade terminal. Supplied with rubber gasket and terminal cover. E-marked. Requires BA9s bulb.



76 x 24mm rectangular repeater lamp. 2 x fixing studs. 6.3mm blade terminal. Supplied with rubber gasket and terminal cover. E-marked. Requires BA9s bulb.

3.85 **171021**



30mm square repeater lamp. Has integral mounting clips. Supplied with rubber gasket and terminal cover. E-marked. Requires BA9s bulb.

4.12 **171022**

INDICATOR KITS

See page 86.



HAZARD KITS

See page 86.



REAR FOG LAMPS

Type



Rear fog lamp that can either be surface mounted or attached with the bracket provided. 130 x 76 x 55mm. E-marked. Requires 12V, 21W bulb (130502).

Each *Part No.*
4.97 **172001**



Rear fog lamp mounted on an adjustable steel bracket. Black plastic body 125 x 80 x 75mm. E-marked. Requires 12V, 21W bulb (130502).

10.87 **172002**



Circular black metal cased rear fog lamp mounted on an adjustable bracket. 122mm diameter. E-marked. Requires 12V, 21W bulb (130502).

16.75 **172003**



Surface mounted modern style rear fog lamp. Connection via 2 pin econoseal socket (051202 - see page 16) which needs to be purchased separately. Supplied with 12V, 21W bulb and sealing gasket. Can be bezel mounted. E-marked.

14.66 **172016**



Mounting bezel for above lamp (172016).

1.85 **170416**

REVERSING LAMPS

Type



Surface mounted modern style reversing lamp. 94mm diameter. Connection via 2 pin econoseal socket (051202 - see page 16) which needs to be purchased separately. Supplied with 12V, 21W bulb and sealing gasket. Can be bezel mounted. E-marked.

Each *Part No.*
14.66 **173016**



Mounting bezel for above lamp (173016).

1.85 **170416**



Circular black metal cased reversing lamp mounted on an adjustable bracket. 122mm diameter. E-marked. Requires 12V, 21W bulb (130502).

16.75 **173003**



Reversing lamp mounted on an adjustable steel bracket. Black plastic body 125 x 80 x 75mm. E-marked. Requires 12V, 21W bulb (130502).

10.87 **173002**

Type



Reversing lamp that can either be surface mounted or attached with the bracket provided. 130 x 76 x 55mm. E-marked. Requires 12V, 21W bulb (130502).

Each *Part No.*
4.97 **173001**

NUMBER PLATE LAMPS

Type



Black plastic number plate lamp. 102 x 55 x 57mm. Requires 12V, 5W bulb (130403).

Each *Part No.*
4.48 **170703**



Black plastic number plate lamp. 83 x 30 x 35mm. Requires 12V, 5W festoon bulb (131702).

4.18 **170704**



Metal based number plate lamp with 2 x BA9s bulbs, supplied. Available with either black plastic cover or chrome-plated cover. Both have plastic lens and rubber sealing gasket. 110 x 45 x 40mm.

Type

Black plastic
Chromed steel

Each *Part No.*
8.01 **170701**
16.00 **170702**



MULTI-FUNCTION AND TRAILER LAMPS



Stop/tail and indicator lamp. Plastic base and plastic lens. 104 x 98 x 50mm. Supplied with fixing bolts and grommet. E-marked. Requires bulbs (130502 & 131002).

Type

With number plate illumination
Without number plate illumination

Each *Part No.*
4.29 **174001**
4.18 **174002**



Stop/tail and indicator lamp. Illumination window for number plate (can be blanked off using supplied plate). 158 x 64 x 51mm. Supplied with grommet. Requires bulbs (2 x 130502 & 1 x 130404).

Type

Left hand
Right hand
Pair

Each *Part No.*
7.70 **174003**
7.70 **174004**
14.30 **174005**



Trailer lighting set. Pair of magnetic multi-function lamps with attached triangular reflectors. Prewired with 7.5m of cable to a standard trailer plug. Supplied with bulbs. Very useful and adaptable set. Plug-in and go.

30.80 **174006**

INTERIOR LAMPS

Type



Recess mounted interior lamp. Plastic construction with integral three position switch. Supplied with 12V, 10W festoon bulb. 143 x 67 x 77mm.

Each *Part No.*
15.50 **176001**



Surface mounted 90mm diameter interior roof lamp. Plastic construction with integral switch. Supplied with 12V, 10W festoon bulb.

10.19 **176007**



Enamelled metal body with plastic lens and integral switch. 353 x 58 x 29 mm. Supplied with 12V, 8W fluorescent tube.

21.38 **176004**

Spare 12V, 8W fluorescent tube for above lamp (176004).

4.96 **176005**

SPARE PARTS FOR LUCAS LAMPS

L594

Item



Amber lens
Clear lens
Red lens
Rubber body
Chromed rim
Bulb holder (single contact, BA15s)
Bulb holder (double contact, BAY15d)

Each *Part No.*
5.90 **177001**
5.90 **177002**
5.90 **177003**
3.00 **178002**
1.95 **178003**
4.20 **132010**
4.20 **132011**

L488

Item



Amber lens
Clear lens
Red lens
Rubber body
Chromed rim
Bulb holder (single contact, BA15s)
Bulb holder (double contact, BAY15d)

Each *Part No.*
5.90 **177004**
5.90 **177005**
5.90 **177006**
3.00 **178001**
1.95 **178003**
4.50 **132012**
4.50 **132013**

L691

Lenses come with mounting screws and gaskets.

Item



Amber lens
Clear lens
Red lens

Each *Part No.*
7.35 **177007**
7.35 **177008**
7.35 **177009**

REFLECTORS

Type



Red triangular with two fixing holes. E-marked.

Each *Part No.*
1.16 **175001**



Red 60mm diameter with fixing hole. E-marked.

0.60 **175002**



Red 83mm diameter with fixing hole. E-marked.

0.91 **175003**



Red 90 x 40mm with two fixing holes. E-marked.

1.09 **175004**



Lucas red reflector having diameter of 55mm. Overall unit diameter 70mm. Fixes to vehicle with self-tapping screw. E-marked.

8.75 **175005**



Red reflector with chrome-plated metal surround. Reflective area 70 x 34mm. 5mm fixing holes on 80mm centres. Overall size 88 x 40mm. E-marked.

7.50 **175006**

FLASHER UNITS & RELAYS

FLASHER UNITS

6 Volt

Type



Electronic 6V relay. 2 x 21W capacity. 3 x 6.3mm blade terminals. Supplied with mounting bracket. Connection details - see page 93.

Each *Part No.*
5.72 **140108**



Good quality 6V indicator relay, made by Bosch. 3 x 6.3mm blade contacts. Comes with mounting bracket and wiring diagram. Can power 2 x 18/21W indicators plus separate dash warning lamp. Negative or positive earth applications. Connection details - see page 92.

20.63 **140106**

contd...

FLASHER UNITS (contd)

12 Volt

Type

Electronic hazard/flasher unit. 2/4 x 21W + 5W capacity. 3 x 6.3mm blade terminals. Supplied with wiring diagram (also shown on page 91). Can be used on both positive and negative earth vehicles. Connection details - see page 92.

Each Part No.
6.75 140102



Electronic hazard/flasher unit. 2/4 x 21W + 5W capacity. 4 x 6.3mm blade terminals. Requires earth. Supplied with wiring diagram. Negative earth only. Connection details - see page 92.

9.48 140103



Lucas SFB105 flasher unit. 46W capacity, 12V. Aluminium can with integral mounting bracket. 3 x 6.3mm blade terminals, marked B (power in), P (warning lamp), and L (flasher signal out). Positive or negative earth applications. Connections details - see page 93.

5.78 140110



Electronic flasher unit that can operate LED indicator lights and conventional bulbs or a mixture of both. Useful when used with LED replacement bulbs. 3 x 6.3mm blade terminals. Negative earth only. Capacity up to 30W. Connection details - see page 92.

9.80 140107



Lucas DB10 style flasher unit. To enable brake lights to also be used as rear indicators. 12V only. 8 x screw terminals. Supplied with wiring diagram. Connection details - see page 92.

60.00 140105



BUZZERS AND ALARMS

Type

Dashboard buzzer. 12V, 2 tone, 72dB(A). More of a warble than a buzz. Single hole fixing. 2 x 6.3mm blade terminals.

Each Part No.
8.36 140401



Lights on warning buzzer. For use behind the dash board to warn of lights having been left on. 3 x 6.3mm blade terminals. 2 tone, 72dB(A). Supplied with wiring diagram.

8.14 140402



Type

Dashboard buzzer. 12V loud and urgent tone. Suitable for use as an indicator warning buzzer, etc. 2 x 6.3mm blade terminals. Polarity sensitive.

Each Part No.
6.00 140403



Back-up alarm with 105 dB(A) intermittent sound. 12V. Made from black plastic with metal fixing bracket. 55mm diameter. CE approved.

11.88 140404



RELAYS

6 Volt Relays (all with mounting lugs)

Type

Make and break. 30A @ 6V. 4 x 6.3mm blade terminals.

Each Part No.
5.72 140217



Change over. 20/30A @ 6V. 5 x 6.3mm blade terminals. Connections as per 140206 (12V change over relay).

11.13 140210



12 Volt Relays (all with mounting lugs except 140209)



Make and break. 40A. 4 x 6.3mm blade terminals.

2.20 140201



Fused make and break. 15A. 4 terminals (6.3mm blade). *NB: This unit will not fit into relay box (140304).*

5.28 140202



Heavy duty make and break. 70A. 4 terminals (2 x 6.3mm and 2 x 9.5mm blades).

6.49 140203



Double make and break. 2 x 15A. 5 terminals (6.3mm blade).

4.62 140204



Twin make and break. 30A. 5 terminals (6.3mm blade).

4.18 140205



Change over. 20/30A. 5 terminals (6.3mm blade).

4.29 140206

Twin make and break. Two 12V make and break relays mounted on one common bracket.

7.04 140212



RELAYS (contd)

12 Volt (contd)

Type



Change over latching relay that can be remotely controlled by a momentarily on switch. For example, use this as a dip switch with a push button switch to change between main beam and dip and vice versa. 12V, 25A with resistor. Relay remains latched when power is lost.

Each Part No.
14.50 **140209**



Extra heavy duty relay 100A @ 12V. Has 2 x M6 stud connectors (for circuit to be switched) and 2 x 6.3mm male blade connectors (trigger connections). Approx. 45mm x 45mm x 45mm, with integral bracket.

11.88 **140211**

NB: This unit will not fit into a relay socket.



Interior light delay relay. Gives 10 seconds delay to interior lights going off. 4 x 6.3mm blade connections. (Supplied with wiring diagram). Connection details - see page 93.

9.06 **140207**



12V timer relay which switches off after 10 minutes. Useful for functions such as heated screens. 5 x 6.3mm blade connections. For wiring connections - see page 93.

9.88 **140270**



Lucas SRB111 (6RA) make and break relay. 20A switching capacity. Normally open. (Supplied with wiring diagram). Connection details - see page 93.

22.50 **140208**



Lucas SRB146 (6RA) change over relay (picture as above). 20A switching capacity. Connection details - see page 93.

27.17 **140214**



Lucas SRB143 (6RA) change over relay. 5 x 6.3mm blade connections. 20A capacity. Connection details - see page 93.

28.60 **140213**



Lucas 33RA make and break relays. 4 terminals. 85 and 86 are coil connections (6.3mm blade), 30 and G switch connections (5mm screw). Available in 12V or 24V, continuous operation or intermittent. Supplied with mounting bracket.

Type	Voltage	Operation	Capacity	Colour	Each	Part No.
SRB600	12V	Continuous	60A	Black	13.72	140232
SRB601	24V	Continuous	40A	Red	13.72	140231
SRB631	12V	Intermittent	60A	Green	14.49	140233
SRB632	24V	Intermittent	40A	Blue	17.76	140234



Micro Relays

These are smaller than standard relays and have no mounting lugs or brackets. Approx. 22 x 13 x 25mm (tall) excluding pins. 12V.



Type
Make and break, 4 terminals (2 x 6.3mm and 2 x 4.8mm blades). 25A.

Each Part No.
3.25 **140261**



Change over relay. 5 terminals (2 x 6.3mm and 3 x 4.8mm blades). 10/20A.

3.85 **140260**

RELAY SOCKETS & BOXES

Fixed sockets which accept a maximum of 9 terminals. Can be clipped together to form a block. Supplied with all terminals.



Type
5 x 6.3mm blade and 4 x 2.8mm blade.

Each Part No.
1.32 **140301**

2 x 9.5mm blade, 3 x 6.3mm blade and 4 x 2.8mm blade.

2.20 **140302**

Flying socket which accepts 5 x 6.3mm blade terminals. Supplied with all terminals.



1.32 **140303**

Relay box which accepts 4 x standard relays. Comes complete with transparent lid, gasket, terminals and terminal locking bar. Terminals are crimped onto wires and then inserted into the base of the relay box. Can be clipped together and to the 16-way fuse box (100110) to form an integrated unit. Relay box size H64 x W123 x D42mm.



16.00 **140304**

Relay socket to take standard relays (having 6.3mm blade terminals) and three blade fuses. Can be clipped together to form a block. Supplied with all terminals.



2.42 **140305**

VOLTAGE REGULATORS & DYNAMO BRUSHES

VOLTAGE REGULATORS

6 Volt

Type



6V. Bosch 0.190.213.032 replacement regulator. Works by regulating to earth. Not suitable for Lucas dynamos.

Each Part No.
38.00 **160402**

VOLTAGE REGULATORS (contd)

12 Volt

Type

Each Part No.

21.00 **160201**

12V, 22A. Replaces Lucas RB106, NCB101, etc. Screw terminals.

21.00 **160202**

12V, 22A. Replaces Lucas RB106, NCB101, etc. Blade terminals.

25.30 **160209**

12V. Replaces NCB144 - 4TR. 3 x 6.3mm blade terminals.

25.30 **160210**

12V. Replaces NCB148 - 4TR. 4 x 6.3mm blade terminals.

19.25 **160203**

12V, 25A. Replaces Lucas RB340, NCB131, NCB133, etc.

19.25 **160204**

12V, 22A. Replaces Lucas RB340, NCB130, etc.

19.36 **160205**

12V, 11A. Replaces Lucas RB340, NCB134, NCB136, etc.

19.80 **160206**

12V, 11A. Replaces Lucas RB108, NCB119, etc.

19.80 **160207**

12V, 11A. Replaces Lucas RB108, NCB118, etc.

25.85 **160401**

12V. Bosch 0190.350.023 replacement dynamo regulator. Also replacement for Bosch 0190.350.026, 038, 039, 054, 055, 061, 062, 068, 069, 079 & 084.

DYNAMO BRUSHES

Type

Pair Part No.

1.45 **180101**

Brushes for Lucas C40 dynamos. Size: 5.5 x 19.05 x 18.2mm.

1.69 **180102**

Brushes for Lucas C39 dynamos. Size: 6.35 x 19.05 x 15.9mm.

TOWING EQUIPMENT

PLUGS & SOCKETS

12N plugs and sockets are the normal type for trailer lights, etc. 12S plugs and sockets are for supplementary applications such as caravan power, etc.

Type

Each Part No.

7 pin metal plug (12N)

2.78 **230101**

7 pin metal socket (12N)

3.27 **230103**

7 pin plastic plug (12N)

2.06 **230102**

7 pin plastic socket (12N)

2.30 **230104**

7 pin plastic plug (12S)

2.06 **230105**

7 pin plastic socket (12S)

2.66 **230106**

PRE-WIRED SOCKETS

Type

Each Part No.

7 pin plastic socket (12N) on mounting plate with 1.5 metres of cable.

7.44 **230201**

7 pin plastic socket (12S) on mounting plate with 1.5 metres of cable.

7.96 **230202**

7 pin plastic socket (12N) and 7 pin plastic socket (12S) mounted on double plate with cable.

14.04 **230203**

SOCKET GASKETS

Rubber gaskets for 7 pin sockets.

Each Part No.

0.85 **230303**

SOCKET MOUNTING PLATES

Type

Each Part No.

Single socket side mounting plate.

1.39 **230301**

Double socket side mounting plate.

2.40 **230302**

TOWING RELAYS



Type

Adjustable audible relay. This unit is designed to make an audible bleep when the vehicle indicators are turned on (only when coupled to a trailer or caravan). The vehicle must have a heavy duty flasher unit. Supplied with wiring diagram. Connection details - see page 95.

Each Part No.
7.92 **230401**



Lucas SRB630 60A split charge relay. Enables connection of second battery and/or fridge. Can be triggered from ignition supply or alternator warning light terminal. Connection details - see page 95.

18.31 **140235**



TRAILER LIGHTS

See "Multi-Function/Trailer Lamps", page 73.

ACCESSORIES



12V FUEL SOLENOID VALVES

Anti-theft 12V solenoid valves for petrol and diesel. Cuts off fuel when not energised. Pressure 0-3 bar. Two sizes available.

Bore Size
3.5mm
6.0mm

Pipe Spigot Dia.
8mm
11mm

Each Part No.
39.06 **250101**
42.13 **250102**



WIPER MOTORS

Universal wiper motor with an on/off switch on rear of aluminium casing. The mounting shaft has an M10 thread along its length and allows the wiper to be fitted to frames up to 84mm thick. The mounting shaft and the co-axial driving shaft can be cut down to suit any frame up to this thickness. Available with either an 85° or 110° travelling arc. 12V.

Arc

110°
85°

Each Part No.
49.45 **190101**
52.50 **190102**

WASHER PUMPS

Type

12V vane-type pump with universal fixing bracket. Connection via 2 x 6.3mm blade terminals.

Each Part No.
13.30 **190201**



Type

12V vane-type pump with metal fixing bracket. Replaces Lucas WSB 100.

Each Part No.
16.50 **190204**



COMBINED WASHER PUMPS & BOTTLES

Type

12V washer pump and bag. Plastic bag (incorporating pump) hangs on metal bracket provided. Supplied with all necessary fittings including push button switch, pipe and nozzles. Approx. 2L capacity.

Each Part No.
16.06 **190202**



12V washer pump and bottle. Rigid plastic bottle incorporating pump with fixing bracket. Approx. 1.2L capacity.

15.50 **190203**

24V version of above.

15.50 **190205**

HORNS

Type

Basic disc horn, diaphragm type. Supplied with bracket. Connection via 2 x 6.3mm blade terminals. 335Hz, 100mm OD, 12V.

Each Part No.
7.70 **200101**



Compact disc horn. 70mm OD. Diaphragm type with red painted steel body. Supplied with bracket. Connection via 2 x 6.3mm blade terminals. 103dB(A), 335 or 420Hz, 12V.

Tone

Low (335Hz)
High (420Hz)

Each Part No.
8.67 **200102**
8.67 **200103**



Type

Twin Marco electric air horns. Red with chrome grilles. Supplied with relay and mounting kit. 12V, 410-510Hz.

Each Part No.
17.60 **200104**



Twin Marco air horns and compressor. Supplied with relay, tube and mounting brackets. Horn lengths 150 and 190mm. 700-850Hz, 12V.

21.00 **200105**

KITS

TERMINAL KITS

Type

Each Part No.
47.50 160101



Insulated Terminal Kit (with Crimping Tool)
Contains 590 insulated terminals (24 types) and a crimping tool. Packed into a robust plastic case with dividers, and fitted with a carrying handle.

25.02 160102



Insulated Terminal Kit
Contains 270 insulated terminals (18 types) packed into a robust plastic case with dividers.

15.35 160109



Non-Insulated Terminal Starter Kit
Contains a selection of non-insulated 6.3mm blade and piggyback terminals and non-insulated ring terminals together with suitable insulation sleeves. 260 pieces in total. Packed in a robust plastic case with dividers.

55.05 160110



Non-Insulated Terminal Professional Kit
Contains a large selection of non-insulated blade, piggyback, ring and 4.7mm bullet terminals, plus insulation sleeves and bullet connectors. 1000 pieces in total. Packed in a robust plastic case with dividers.

28.50 160106



Bullet Kit (Non-Insulated)
175 bullets (4.7mm dia) suitable for crimping or soldering in four different wire sizes (0.65 - 3.00 mm²), together with 50 single and 25 double bullet connectors. Supplied in a robust plastic case with dividers.

Each Part No.
35.04 160107
59.24 160108

HT Terminal Kit

Contains a selection of straight and 90° HT spark plug and distributor/coil terminals and covers. 133 items in total. Packed in a robust plastic case with dividers. Contents easily sufficient to make six 4-cylinder vehicle HT lead sets.

Type

Kit on its own
Kit plus crimping tool (150601, page 87)

GROMMET KITS

Type

Each Part No.
18.50 160104



Wiring Grommet Kit

Contains a selection of 180 wiring grommets (for panel hole sizes from 6.4mm to 25.2mm) packed into a robust plastic case with dividers.



Blanking Grommet Kit

Contains a selection of 180 blanking grommets (for panel hole sizes from 6.4mm to 22.5mm) packed into a robust plastic case with dividers.

18.50 160105

FUSE KITS

Type

Each Part No.
23.20 160103



General Fuse Kit

Contains 200 popular automotive fuses. A selection of blade, continental and glass fuses packed into a robust plastic case with dividers.



Older Vehicle Fuse Kit

Contains 180 assorted continental and glass fuses packed into a robust plastic case with dividers.

15.50 160111



Blade Fuse Kit

Contains 100 popular-sized blade fuses packed into a robust plastic case with dividers.

13.70 160112



MULTIPLE CONNECTOR KIT

Contains a selection of 70 pairs of 6.3mm blade multiple connector housings (as seen on page 15), from 1 to 11 ways. Supplied with 400 terminals. Packed into a robust plastic case with dividers.

51.03 160115

P-CLIP KITS

Type

Each Part No.
33.20 160113



Brass P-Clip Kit

Contains a selection of 80 brass p-clips, ranging in size from 5mm to 22mm. Packed into a robust plastic case with dividers.

P-CLIP KITS (contd)

Type

Nylon P-Clip Kit

Contains a selection of 240 nylon p-clips, ranging in size from 3.2mm to 19.4mm. Packed into a robust plastic case with dividers.

Each Part No.
14.52 160114



Steel P-Clip Kit

Contains a selection of 95 rubber-lined steel p-clips ranging in size from 6.4mm to 25.4mm. Packed into a robust plastic case with dividers.

31.42 160116



INDICATOR KITS

LED Indicator Kit (12V only)

A complete kit of parts to enable you to fit indicators to any 12V vehicle (+ve or -ve earth). Includes 4 x Rubbolite lamps fitted with LED bulbs, 20m twin core cable, flasher relay, dashboard switch, warning light and bracket, crimp terminals and wiring diagram. The power taken for this kit is only approximately 5W (0.3A), so it is ideal for cars with limited or no charging systems, and the LED bulbs are extremely long lasting. Connection details - see page 94.

Each Part No.
79.00 170805



Indicator Kit without Lamps

These kits include all the parts you need (except the lamps) to fit indicators to any vehicle. The kits include 20m twin core cable, flasher relay, dashboard switch, warning light and bracket, crimp terminals and wiring diagram. Available in 6V or 12V. Both kits require the addition of 4 x 21W indicator lamps (see pages 70 & 71). Connection details - see pages 93 & 94.

Type

6V
12V

Each Part No.
22.00 170803
22.00 170804



HAZARD SWITCH KITS

A kit of parts to enable you to convert existing 12V indicators to hazards at the flick of a switch. Kit includes flasher relay, warning lamp, switch, bracket, crimp terminals and wiring diagram. Only available in 12V. For use with either standard or LED-type indicators. Connection details - see page 95.

Type

Standard bulbs
LED bulbs

Each Part No.
15.00 170902
22.00 170903



TOOLS

EXPANDING SLEEVE APPLICATION TOOL

Each Part No.
34.43 150102

This tool is suitable for applying neoprene expandable sleeves, by stretching them during application.



CRIMPING TOOLS For Insulated Terminals

Type

Economy tool for crimping the full range of insulated terminals. Also features a wire stripper and cable cutter.

Each Part No.
2.98 150201



Tool for crimping the full range of insulated terminals and many non-insulated terminals. Also features a wire stripper, cable cutter and cushion handles.

4.86 150202



Heavy duty ratchet tool for crimping the full range of insulated terminals. This tool ensures the correct pressure is applied whilst crimping the terminal.

24.20 150203



For Non-Insulated Terminals

Type

Economy tool for crimping many non-insulated terminals. Also features wire stripper and cable cutter.

Each Part No.
3.37 150204



Robust and heavy duty tool for crimping many non-insulated terminals. Also features wire stripper and cable cutter.

10.84 150205



Ratchet tool for crimping many non-insulated terminals. This tool ensures the correct pressure is applied whilst crimping the terminal.

28.92 150206



Heavy duty ratchet tool for crimping HT terminals (such as those shown on page 20) to HT cable.

27.76 150601



Ratchet crimping tool for 4 sizes (10, 16, 25 & 40 sq mm) of open end and closed end battery cable terminals. Overall length of tool 325mm.

49.50 150209





BULLET TOOLS

Type

Bullet crimping tool for non-insulated bullets.

Each Part No.
23.10 150207



Bullet inserting tool for inserting soldered or crimped bullets into connectors.

15.50 150301

CABLE STRIPPERS

Type



Automatic cable strippers and cutters for cables between 0.5 and 6.0mm². This tool is also suitable for crimping insulated and non-insulated terminals.

Each Part No.
11.49 150401



Automatic cable strippers for cables between 0.5 and 3.0mm².

12.97 150402



CABLE CUTTERS

Heavy duty cable cutter for cutting copper cables up to 70mm². Tool length 235mm.

Each Part No.
16.38 150501



For cutting copper cable up to 1.6mm diameter. 125mm length, jaw length 13mm. 45 degree blade angle. PVC handle covers, medium carbon steel construction.

7.97 150701

SOLDERING



SOLDER

Type

Fluxed core solder. 18 swg (1.2mm diameter). 500g roll.

Each Part No.
18.30 220101



5 metres of the above (approx. 40g).

2.05 220102



FLUX

"Fluxite" soldering paste. Contains zinc and ammonium chlorides in petroleum grease. 100g tin.

Each Part No.
7.44 220201



SOLDERING IRONS & ACCESSORIES

Item

Antex XS25. 25W, 240V soldering iron. British made to EN-60335-2-45. Supplied with 1.5m of cable and 3mm diameter replaceable tip (see 220303).

Each Part No.
18.40 220301



Antex MLXS25. 25W, 12V soldering iron. British made to EN-60335-2-45. Supplied with 4m of cable with crocodile clips to power from a car battery. 3mm diameter replaceable tip (220303).

24.20 220302



3mm diameter replacement tip for XS25 and MLXS25.

3.70 220303



Soldering iron bench stand ST4.

6.08 220304



Antex GASCAT60 gas (butane) soldering iron. Supplied with 2.4mm diameter tip and safety cap with integral lighting flint. Spare tips available (see 220402 and 220403).

28.90 220401



Spare tips for GASCAT60.

Type

2.4mm diameter
4.8mm diameter

Each Part No.
8.04 220402
8.04 220403



Antex GASCAT60 gas soldering iron kit. Contains GASCAT60 iron (220401) plus hot air tip, flame tip, hot knife tip and sponge in plastic case.

49.77 220404



Solder sucker. Aluminium pump with teflon tip.

6.48 220501

TESTING/CHARGING



Item

12V vehicle charging tester. This unit indicates, using a series of LEDs, the state of charge of the battery, and also whether the charging system is working correctly. Hand held, but will also magnetically attach to any ferrous surface. Supplied with probe and alligator clip connections.

Each Part No.
24.53 **240101**



Screw driver circuit tester, for voltage testing on 6V, 12V and 24V systems.

2.95 **240102**



Chrome plated brass circuit tester, for voltage testing on 6V, 12V and 24V systems.

4.62 **240103**



Induction ammeter. 30-0-30 Amps. Indicates approximate current and direction when clipped to cables. 57mm dia.

18.20 **240104**



ACCUMATE 6/12V BATTERY CONDITIONER

Designed to automatically charge and monitor batteries with no danger of over-charging regardless of time. Suitable for all 6 and 12V lead acid batteries from 4Ah to 75Ah, making it perfect for owners of older vehicles which are not used on a daily basis. Operation is completely automatic. The unit uses a 1.2A constant current charge as the main stage, while monitoring the battery voltage. When this reaches a pre-set cut off point, it then switches to an intermediate constant voltage 'float charge'. Only when it has detected that the battery is properly charged, will it switch to the final stage for correct long-term battery maintenance. If at any time it detects that the battery has discharged, it will automatically revert to the constant current stage.

Each Part No.
36.30 **210107**



Accumate lead adapter, to enable connection to the vehicle via the cigarette lighter socket.

9.08 **210108**

WIRING DIAGRAMS

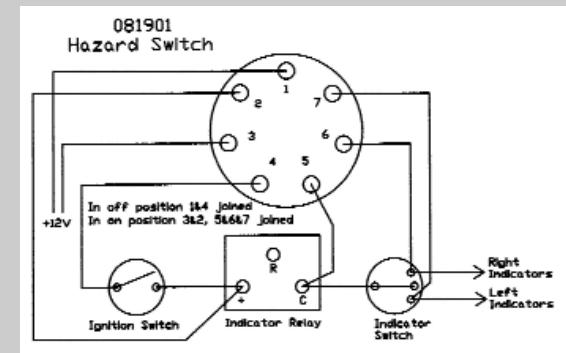
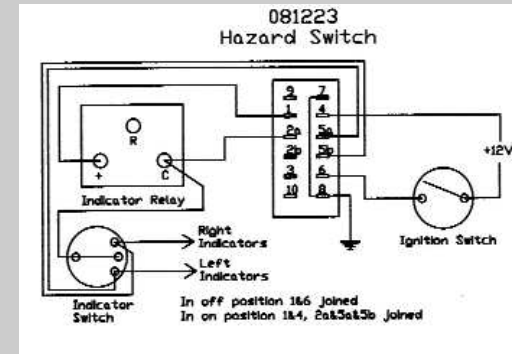
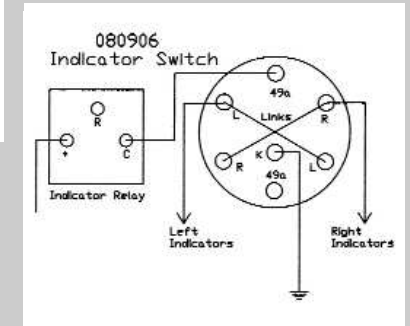
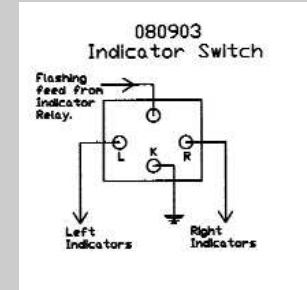
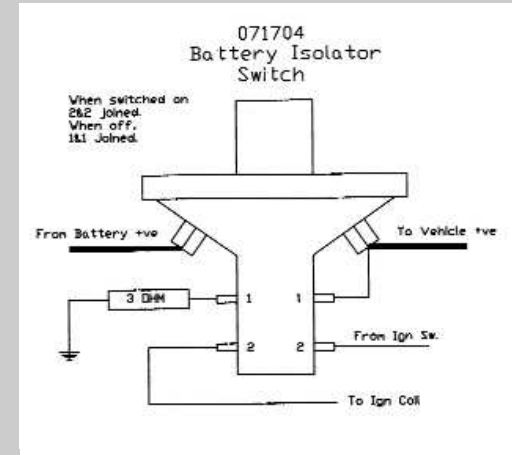

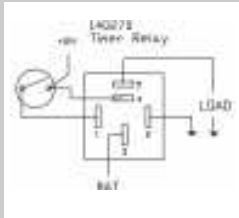
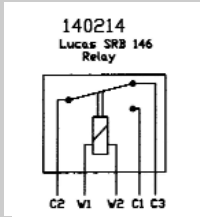
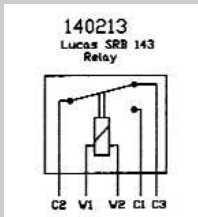
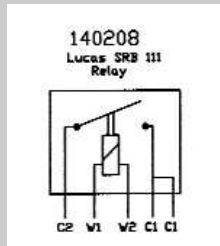
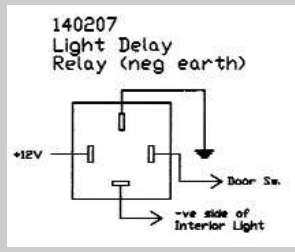
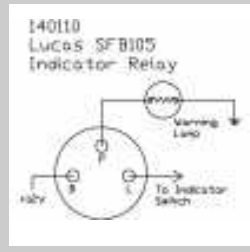
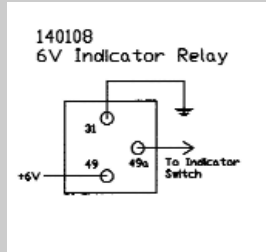
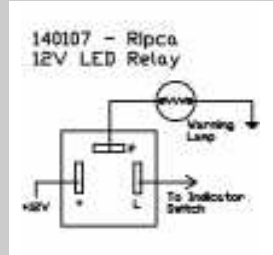
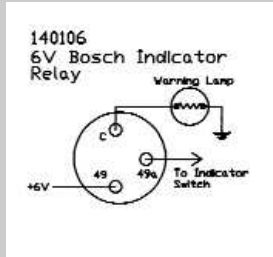
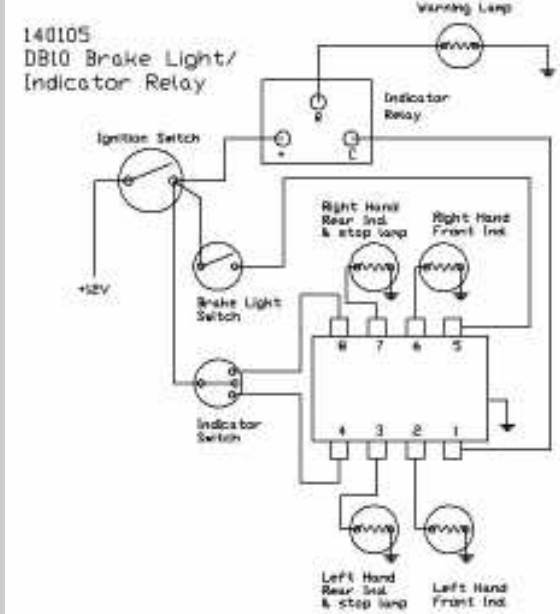
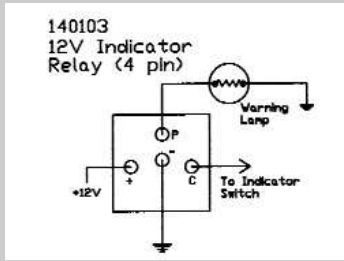
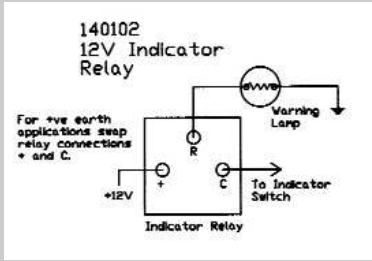
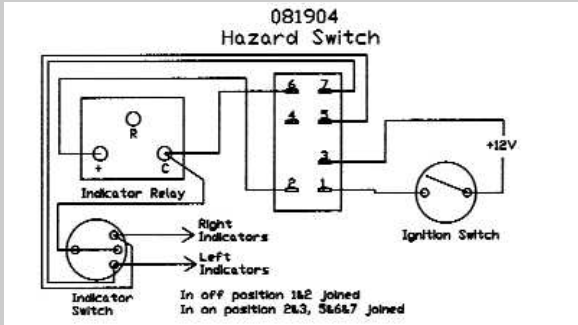

Alternative Relay Markings

Power In:	+, 49, X
Flashing Signal Out:	C, 49a, L
Warning Lamp:	R, P
Earth:	-, 31, K

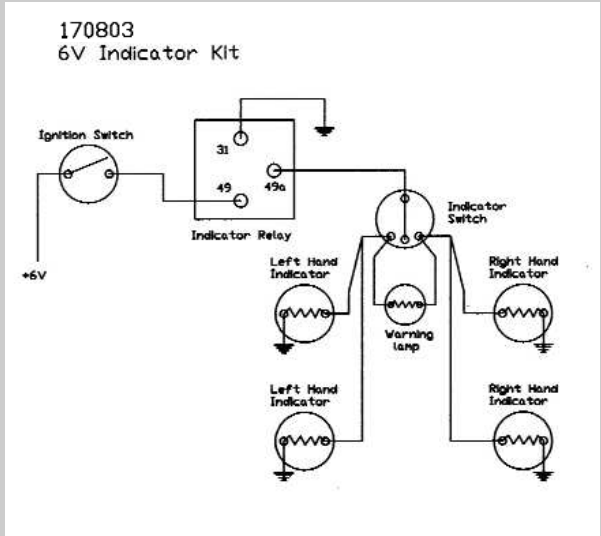

170804
12V Indicator Kit

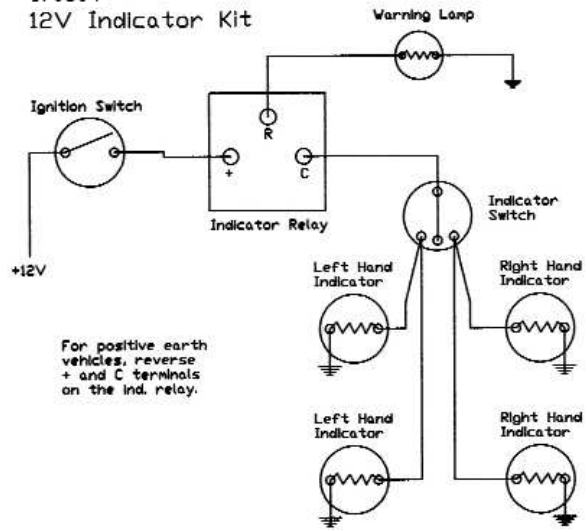

170805
12V LED Indicator Kit (Ripca)

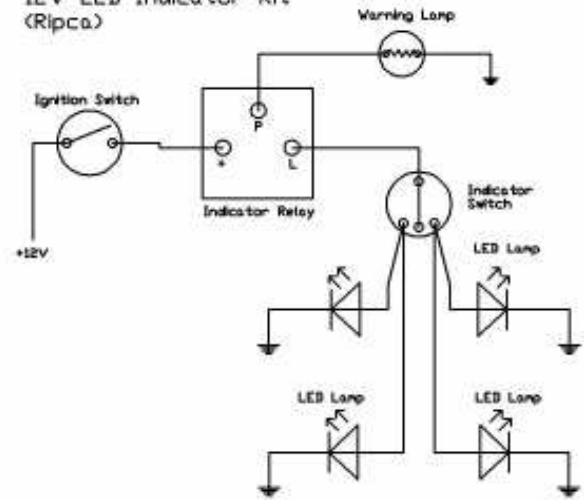

170902
12V Hazard Kit

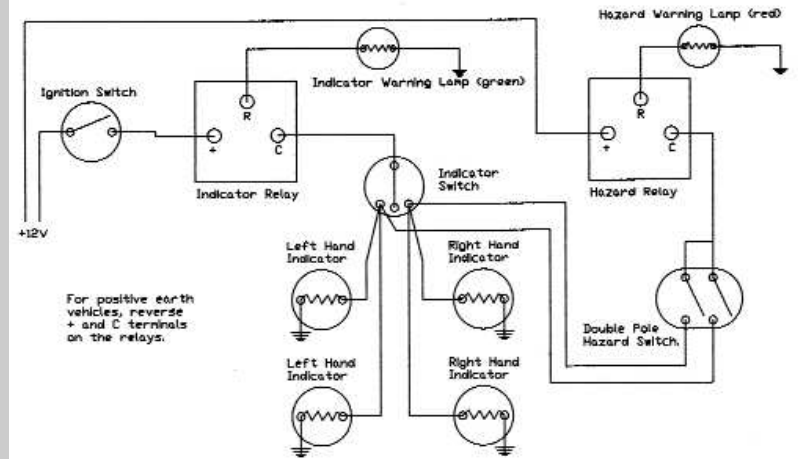

170903
12V LED Hazard Kit (Ripca)

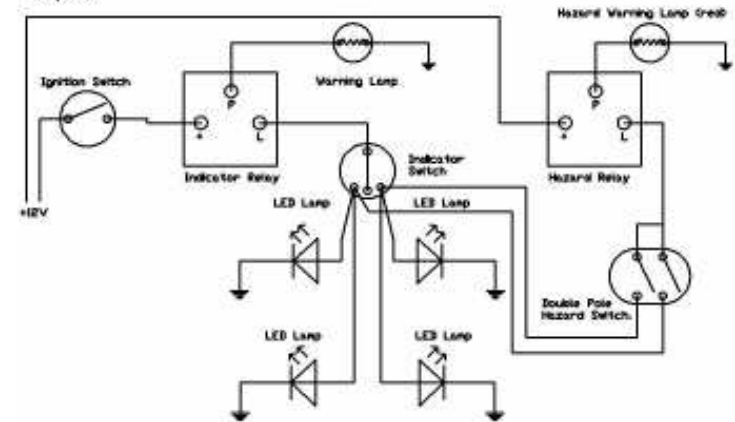

230401
Audible Relay

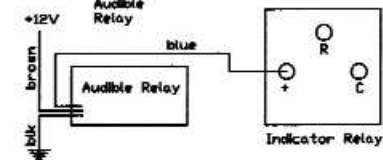

140235
Lucas SR8 360
Split Charge Relay

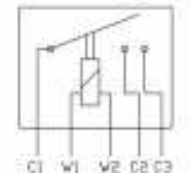

NOTES

INDEX

Alternator Plug	18	Ignition Coils - Acorn Terminal	21
Battery Accessories	22	Ignition Coils - Lucas	21
Battery Cable Connectors	24	Ignition Coils - Standard	21
Battery Cable Terminals & Covers	25-26	Ignition Lead - Braided	8
Battery Cables (Preformed)	26-27	Ignition Lead - Standard	4
Battery Clamps & Covers	23-24	Ignition Lead Markers	20
Battery Conditioner	90	Ignition Lead Separators	20
Battery Isolator Switches	28-29	Indicator Kits	86
Bonding Straps	27	Isolator Switches	28-29
Braided Cable	6-8	Junction Boxes	44
Braided Sleeving	51	Kits	84-86
Brake Light Switches	41	Lamps - Headlamps	64-65
Buckle Clips	54	Lamps - Indicator	70-71
Bulb Holders	61-63	Lamps - Indicator Repeater	71
Bulbs	57-61	Lamps - Interior	74
Bullets (Solder & Crimp On)	10-11	Lamps - Number Plate Lamps	73
Buzzers & Alarms	76-77	Lamps - Rear Fog Lamps	72
Cable - Battery (Braided)	8	Lamps - Rear Lamps	66-68
Cable - Battery (PVC)	4	Lamps - Reversing Lamps	72-73
Cable - Braided	6-7	Lamps - Side Lamps	68-69
Cable - Ignition (Braided)	8	Lamps - Lucas Spare Parts	74
Cable - Ignition (Standard)	4	Lamps - Trailer Lamps	73
Cable - PVC (Standard)	2	LED bulbs	59
Cable - PVC (Thin Wall)	5-6	Multiple Connector Kit	85
Cable - Multicore (Braided)	8	Neoprene Sleeves	51
Cable - Multicore (PVC)	3	P-Clip Kits	85-86
Cable - Trailer	3	P-Clips	52-53
Cable Markers	51-52	Power Connectors & Handles	27
Cable Strippers	88	Reflectors	75
Cable Ties & Mounts	54-55	Regulators	79-80
Chassis Clips	53-54	Relay Sockets & Boxes	79
Cigar Lighters & Brackets	42-43	Relays	77-79
Circuit Breakers	49	Sleeving	49-51
Condensers	22	Solder	88
Connectors - General	18-19	Soldering Irons & Accessories	89
Connectors - Multiple Connectors	14-16	Spark Plug Caps	20
Connectors - Waterproof	16-18	Spark Plug Terminals & Covers	19
Crimping Tools	87	Spiral Binding	49
DIN Sockets & Plugs	43	Starter Switches/Solenoids	30
Dip Switches	39	Switches - Door	35
Distributor/Coil Acorns	19	Switches - Hazard	37
Distributor/Coil Terminals & Covers	20	Switches - Indicator	35-36
Dynamo Brushes	80	Switches - Key	38
Earth Straps	27	Switches - Push Button	34-35
Flasher Units	75-76	Switches - Push/Pull	33
Flux	89	Switches - Rocker	39-40
Fuse Boxes	44-46	Switches - Rotary	37-38
Fuse Holders	46-47	Switches - Toggle	30-32
Fuse Kits	85	Tape	56
Fuses	49	Terminal Kits	84
Grommet Kits	85	Terminals - Heatshrink Insulated	13-14
Grommets & Grommet Strip	55-56	Terminals - Insulated	11-13
Headlamp Accessories	63-65	Terminals - Non-Insulated	8-10
Headlamp Connecting Sockets	18	Testing Equipment	90
Headlamps	64-65	Tools	87-88
Heat Shrink Sleeving	50	Towing Equipment (Plugs, Sockets, etc)	81-82
Horns	83	Voltage Regulators	79-80
HT Cable - Braided	8	Warning Lamps	42
HT Cable - Standard	4	Washer Pumps & Bottles	82-83
HT Terminal Kit	84	Wiper Motors	82
HT Tester	21	Wiring Diagrams	91-95



**HEREFORDSHIRE
VINTAGE AUCTIONS**

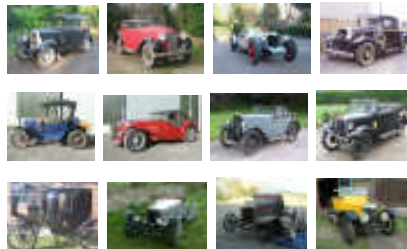

"Probably the country's leading auctioneers of automobilia..."
We also sell vintage and interesting pre 1960 vehicles...

Four auctions a year at How Caple Court, Herefordshire
A SALE FOR ENTHUSIASTS RUN BY ENTHUSIASTS
Office: Hampton Dene, Hereford HR1 1UX

Telephone: 01432 273373
Email: info@hvauctions.com
Web: www.hvauctions.com

HughesMedia

Internet Limited

We build really good websites

call us now on
01584 881 686

Hughes Media Internet Ltd
Orleton House, Orleton
Stanford Bridge, Worcester
WR6 6SU

info@hughesmedia.co.uk
www.hughesmedia.co.uk



PIRELLI
DUNLOP
BUFFALO BOVINGTON
www.longstonetyres.co.uk

Longstone
CLASSIC
TYRES

Tel: +44 (0) 1302 711 123